

User Manual

JAXPETY

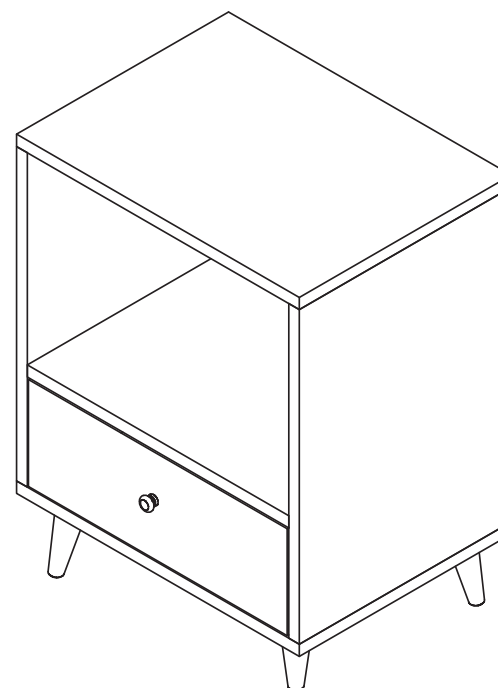

Scan ! To find more surprise!

You need

1 Tools required

A Phillips head screwdriver is required for the assembly of this product. (not included)

Power tools should not be used to assemble this product.







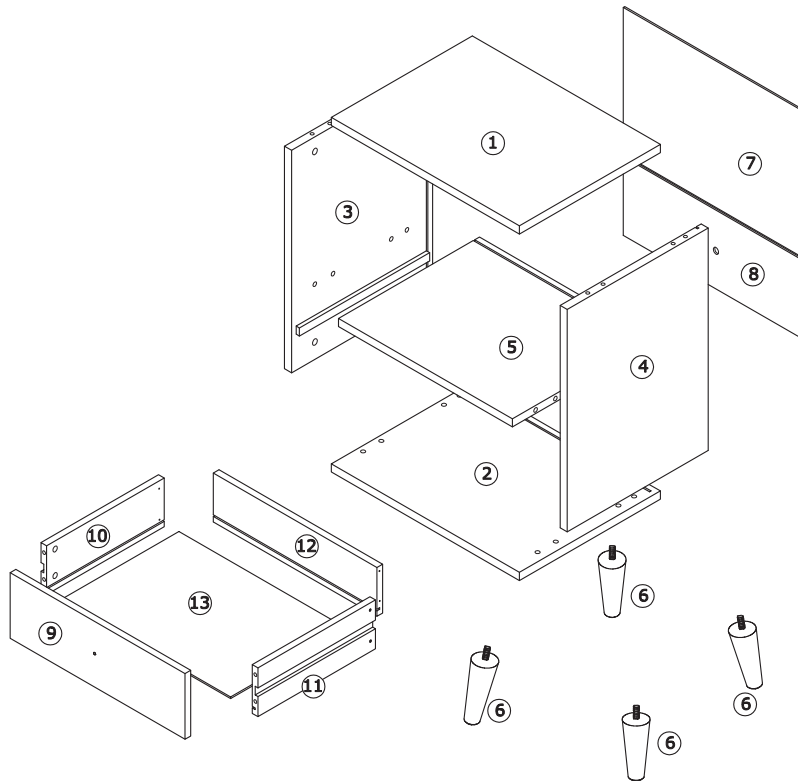



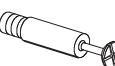

2 1 person is needed

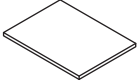
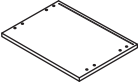
3 Take 30 minutes

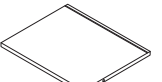
Technical Specifications	
Brand	JAXPETY
Size	403*543*302mm

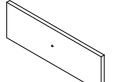
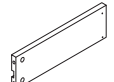

Hardware List

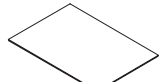
 A 16PCS	 B 16PCS	 C 4PCS	 D 12PCS
 E 1PC	 F 1PC	 1 1PC	 2 1PC
 3 1PC	 4 1PC	 5 1PC	 6 4PCS
 7 1PC	 8 1PC	 9 1PC	 10 1PC
 11 1PC	 12 1PC	 13 1PC	

PRODUCT ASSEMBLY

! Check the package contents before getting started !

STEP 1

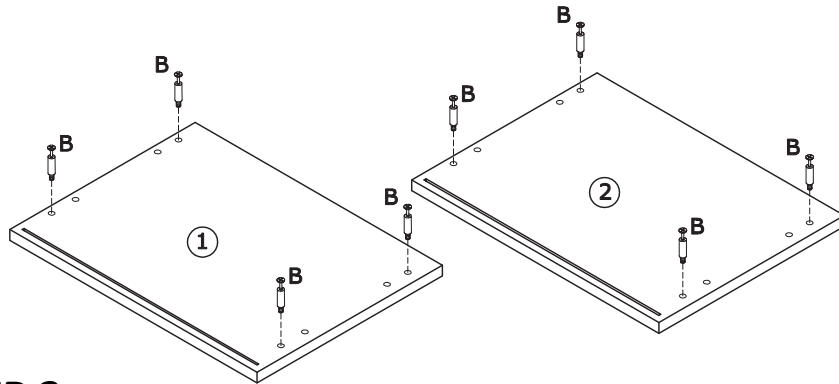
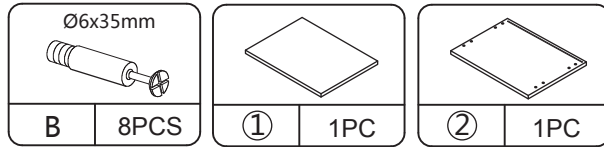

STEP 2

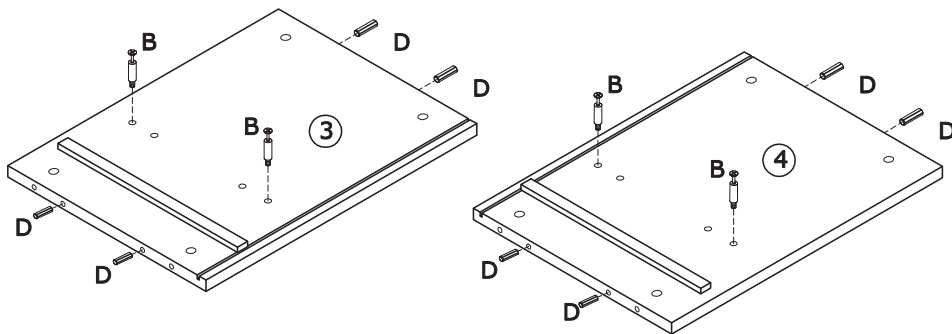
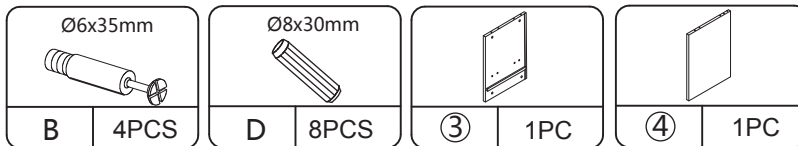

PRODUCT ASSEMBLY

STEP 3

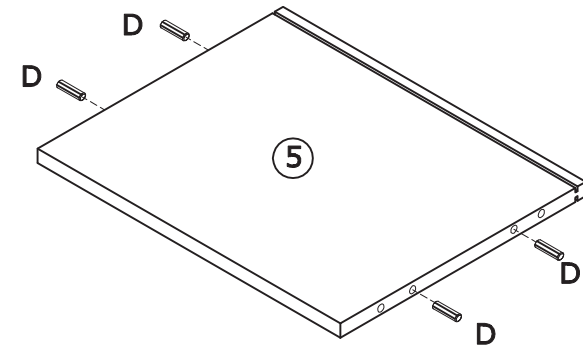
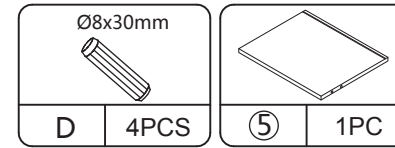

STEP 4

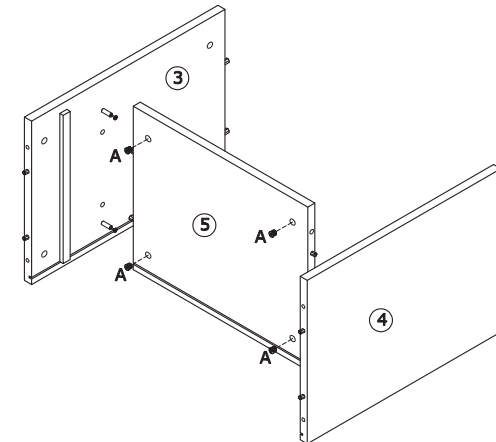
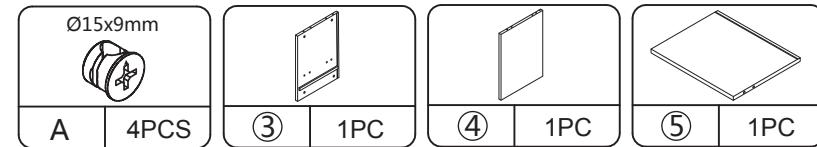

PRODUCT ASSEMBLY

STEP 5

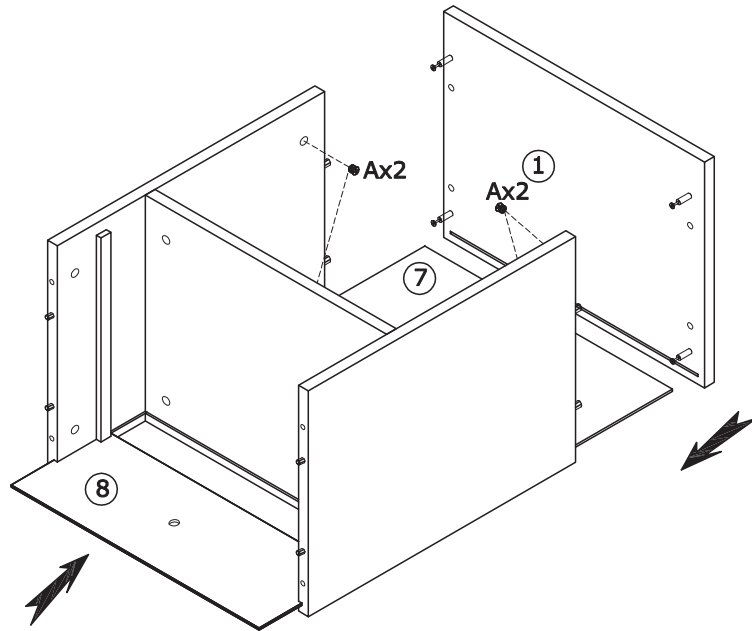
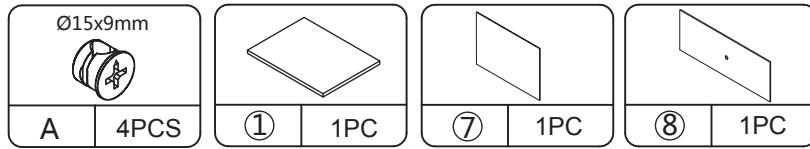

PRODUCT ASSEMBLY

STEP 6

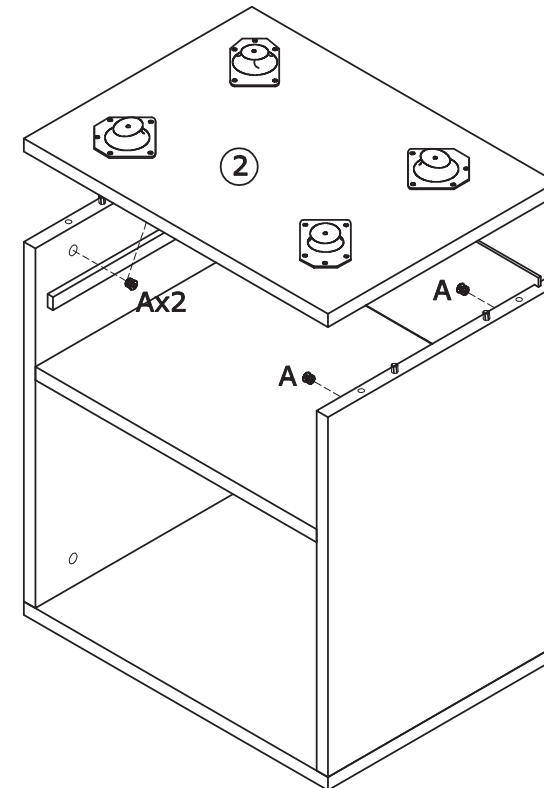
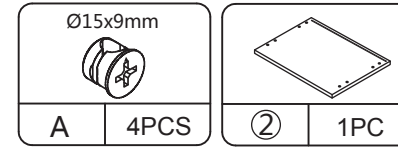

PRODUCT ASSEMBLY

STEP 7

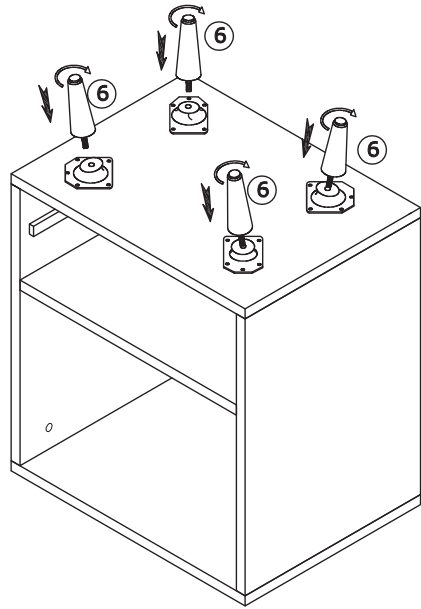
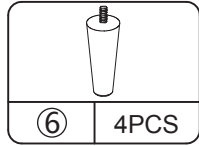

STEP 8

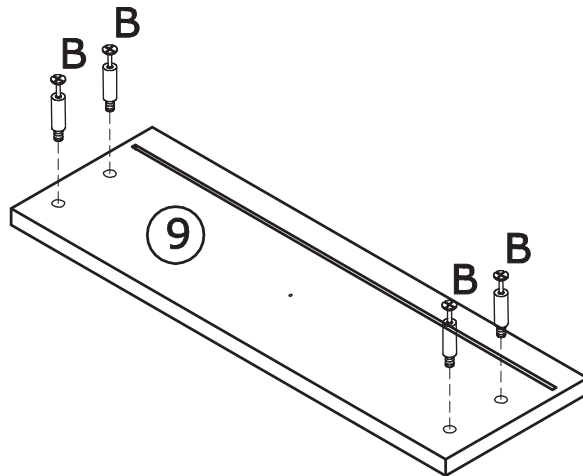
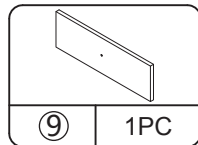
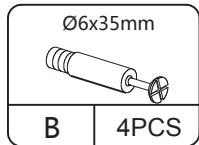

PRODUCT ASSEMBLY

STEP 9

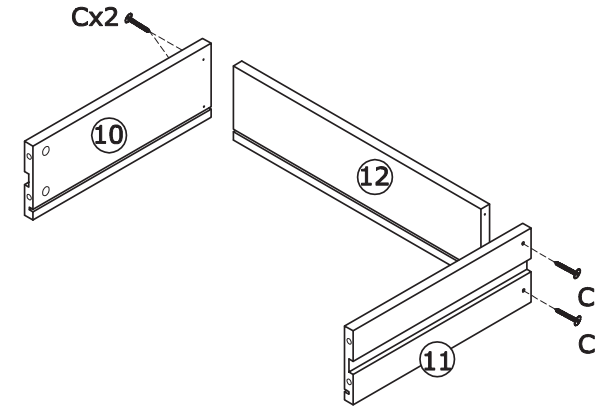
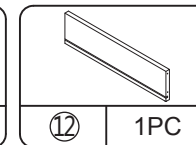
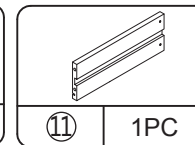
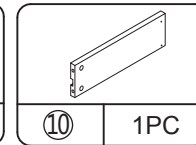
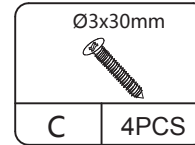

STEP 10

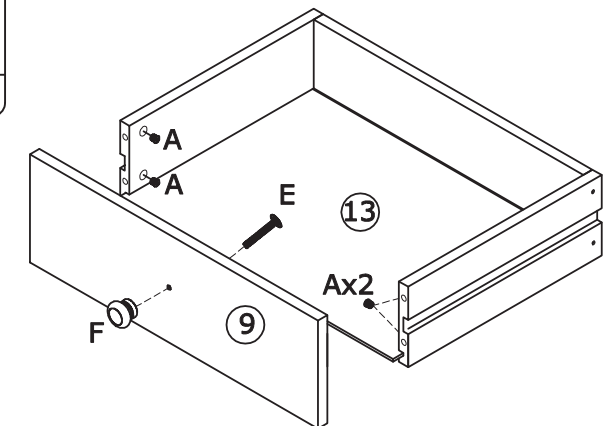
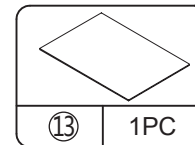
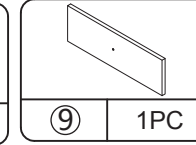
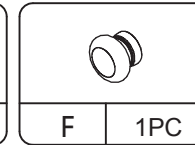
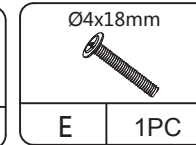
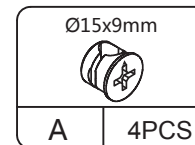

STEP 11

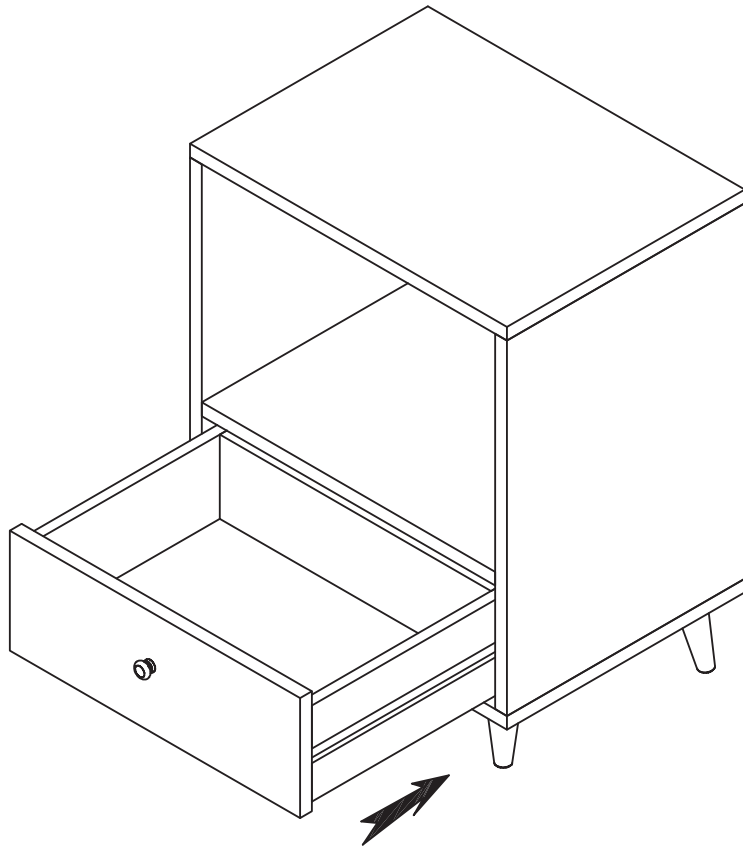

STEP 12

