

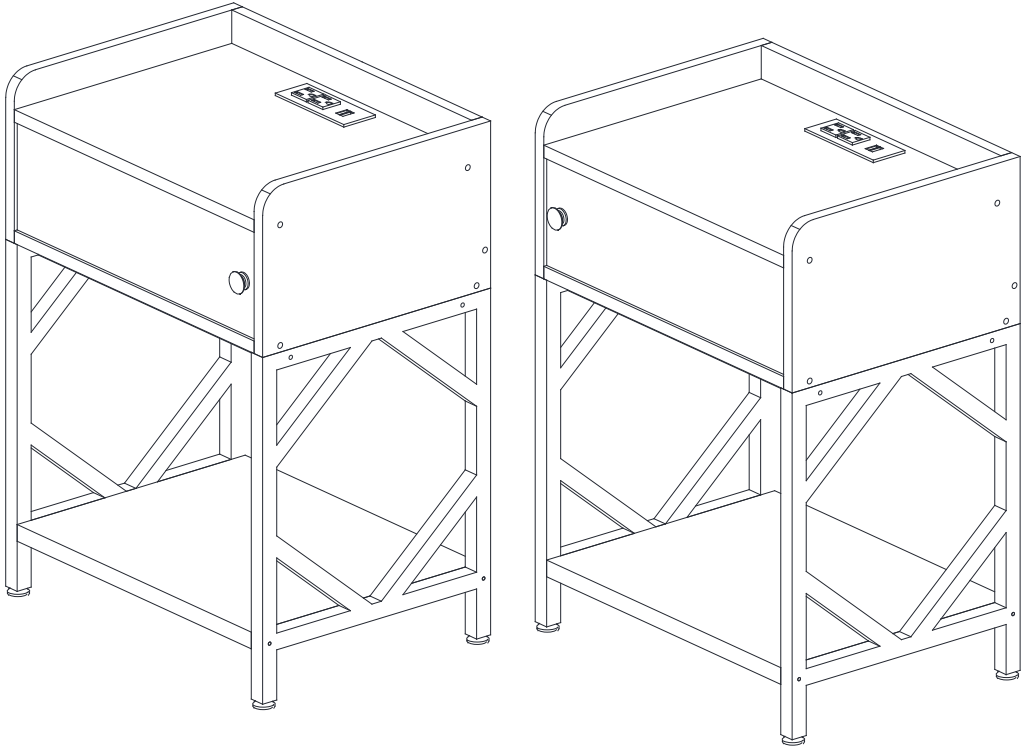

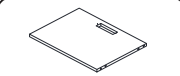

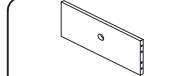

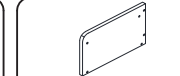



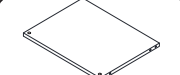

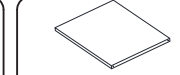

User Manual

JAXPETY

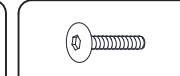
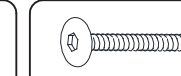
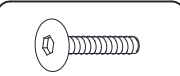

Hardware List

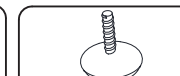
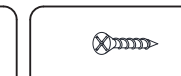
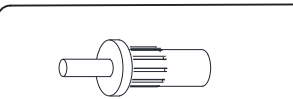
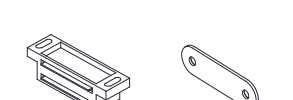
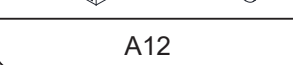
 394X314.5X15mm ① 2PCS	 394X181.5X15mm ② 2PCS	 330X197X15mm ③ 2PCS	 330X197X15mm ④ 2PCS
 394X314.5X15mm ⑤ 2PCS	 390X122X15mm ⑥ 2PCS	 384X330X15mm ⑦ 2PCS	 404X330X20mm ⑧ 4PCS
 384X20X20mm ⑨ 4PCS	 ⑩ 2PCS	 ⑪ 24PCS	 M4X35mm A1 24PCS
 8X30mm A2&A3 24PCS	 M4X20mm A4 2PCS	 M6X30mm A5 8PCS	 M6X45 A6 8PCS
 M6X35 A7 8PCS	 M6X11mm A8 8PCS	 M6X13mm A9&A10 8PCS	 M3X10mm A11 12PCS
		A12-1	4PCS
		A12-2	2PCS
		A12-3	2PCS

You need

① Tools required

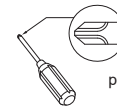

A Phillips head screwdriver is required for the assembly of this product. (not included)

Power tools should not be used to assemble this product.

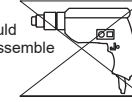

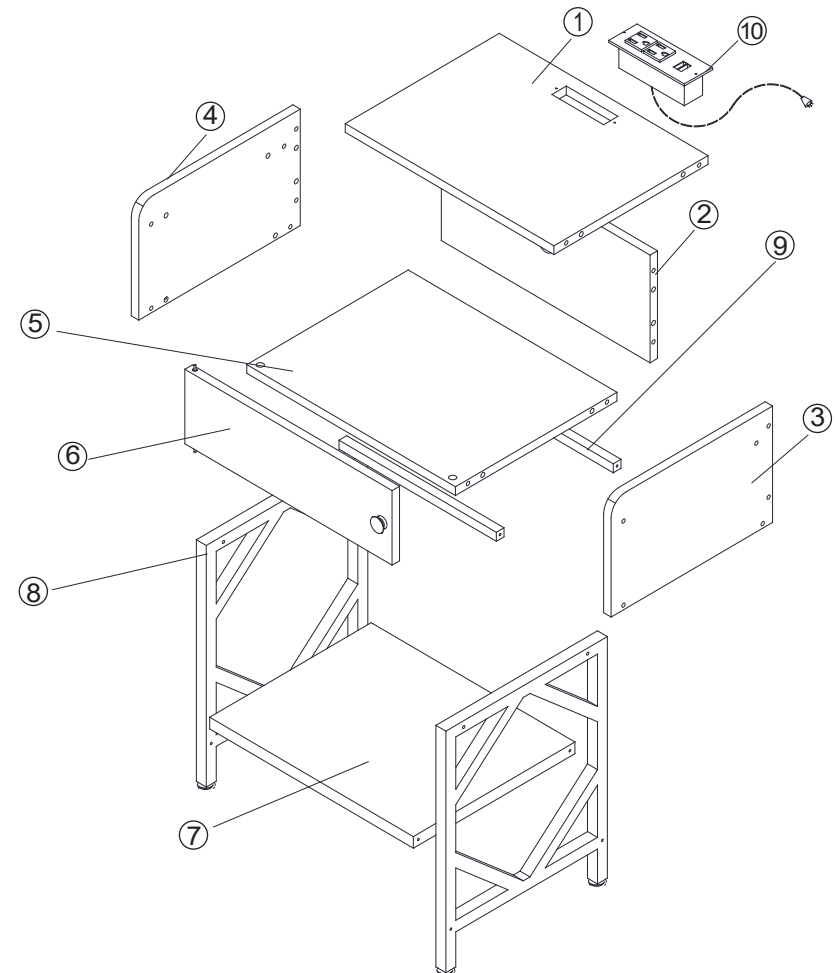

② 1 person is needed



PRODUCT ASSEMBLY

⚠ Check the package contents before getting started !

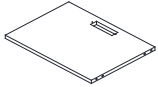
STEP 1

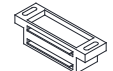
	 M3*10	
① 1PC	A11 2PCS	A12-3 1PC

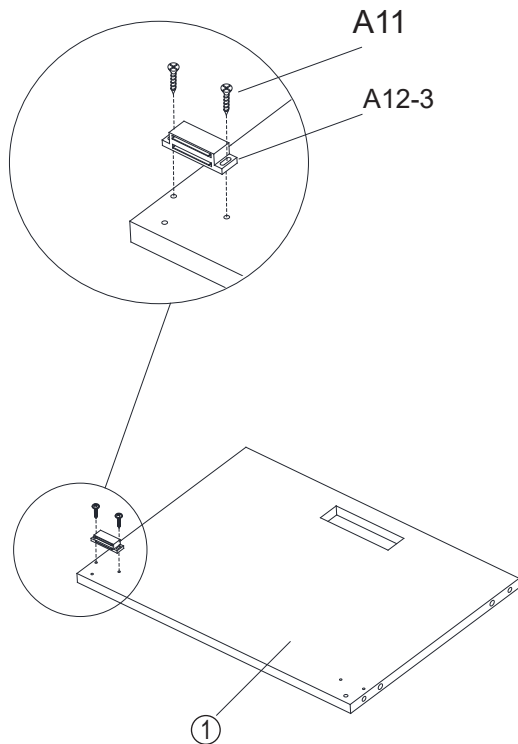

Note: According to your needs, the door can also be installed on the other side in the same way.

PRODUCT ASSEMBLY

STEP 2

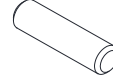
A2&A3 4PCS

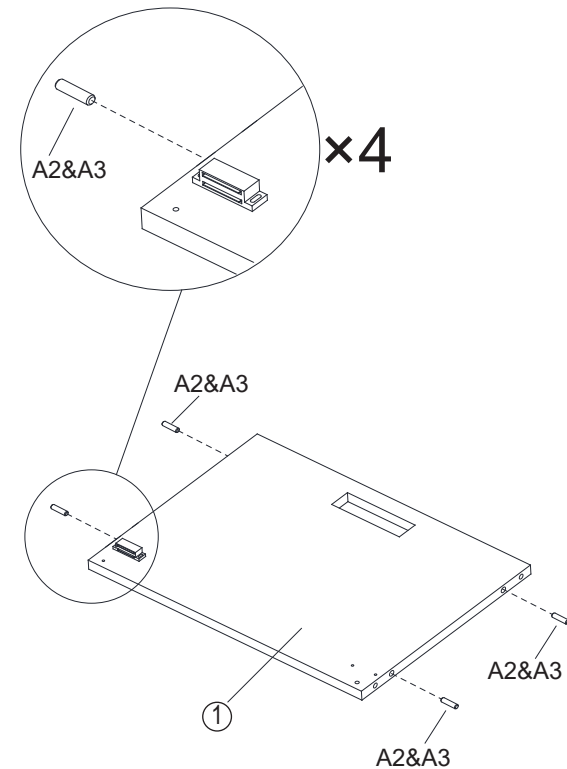

PRODUCT ASSEMBLY

STEP 2

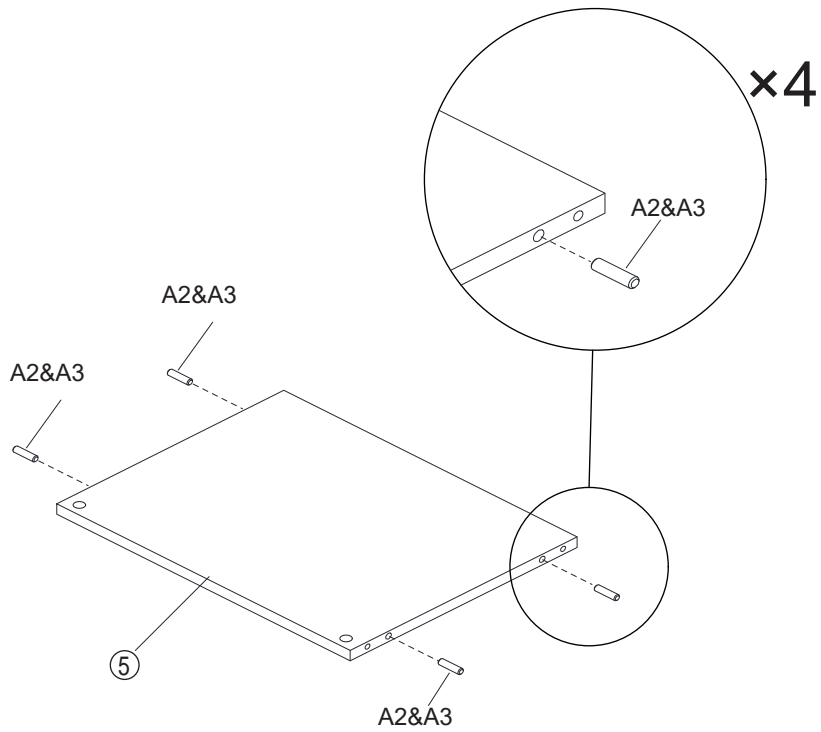
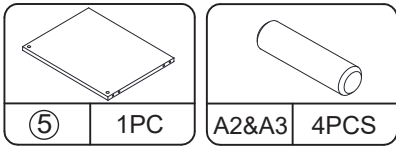

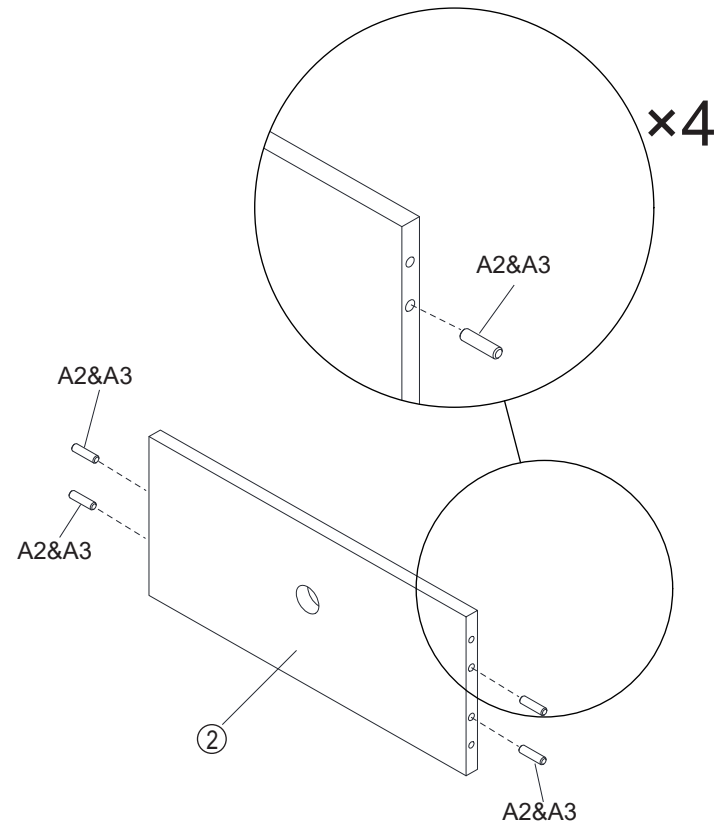
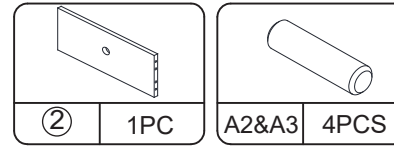

PRODUCT ASSEMBLY

STEP 3



PRODUCT ASSEMBLY

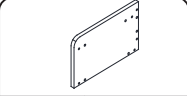

STEP 2

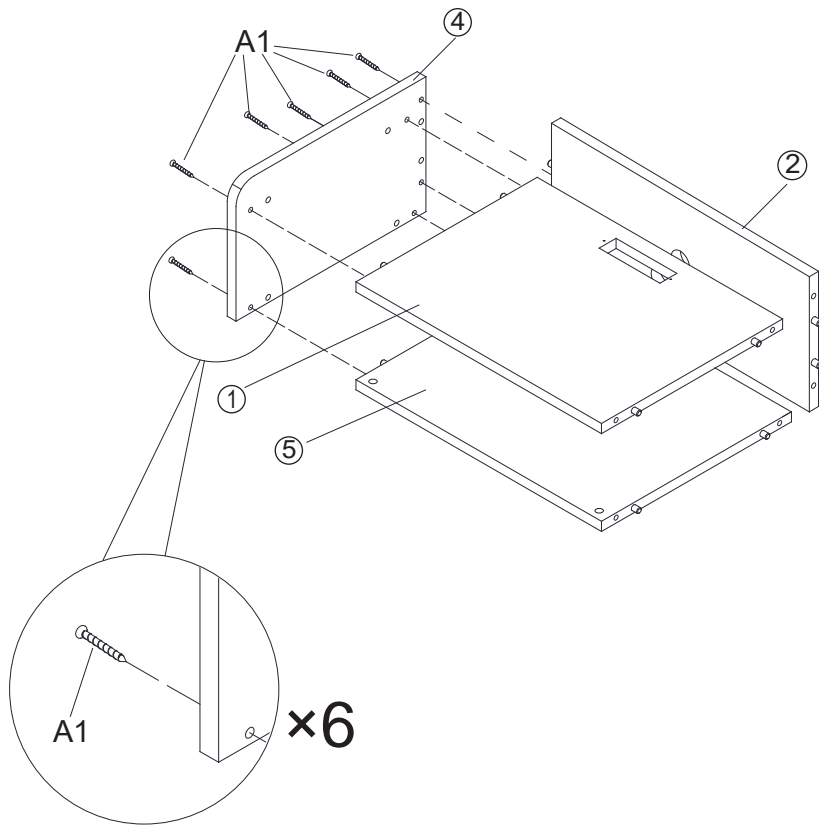
	
④ 1PC	A1 6PCS

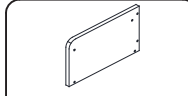

PRODUCT ASSEMBLY

STEP 3

	
③ 1PC	A1 6PCS

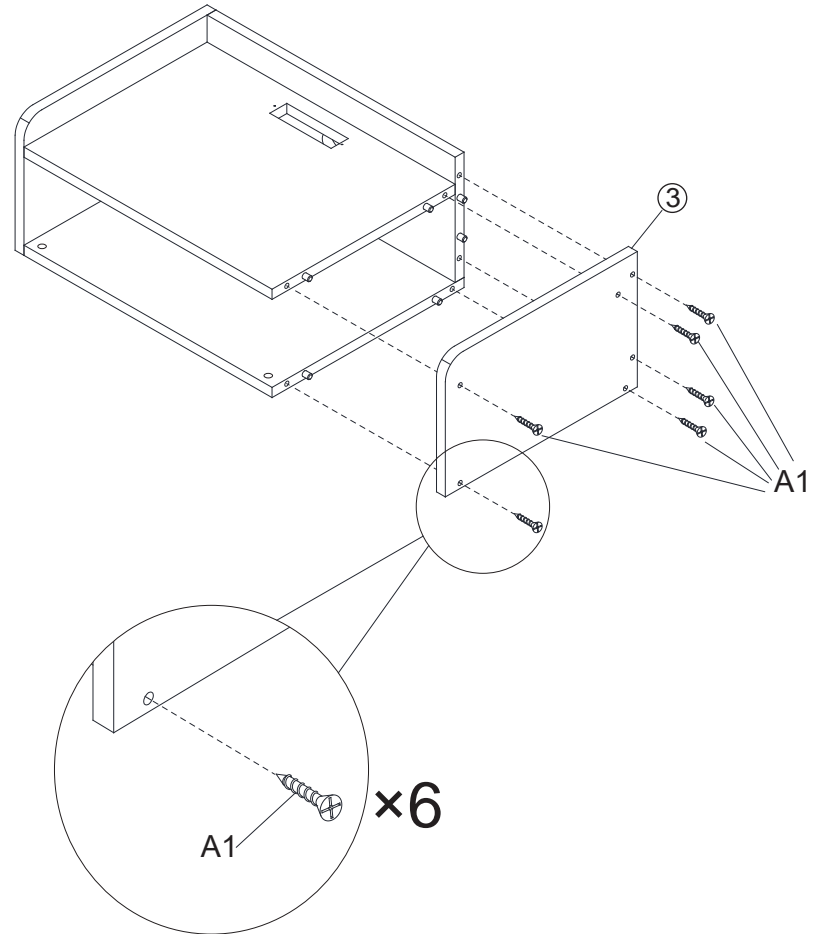

STEP 4

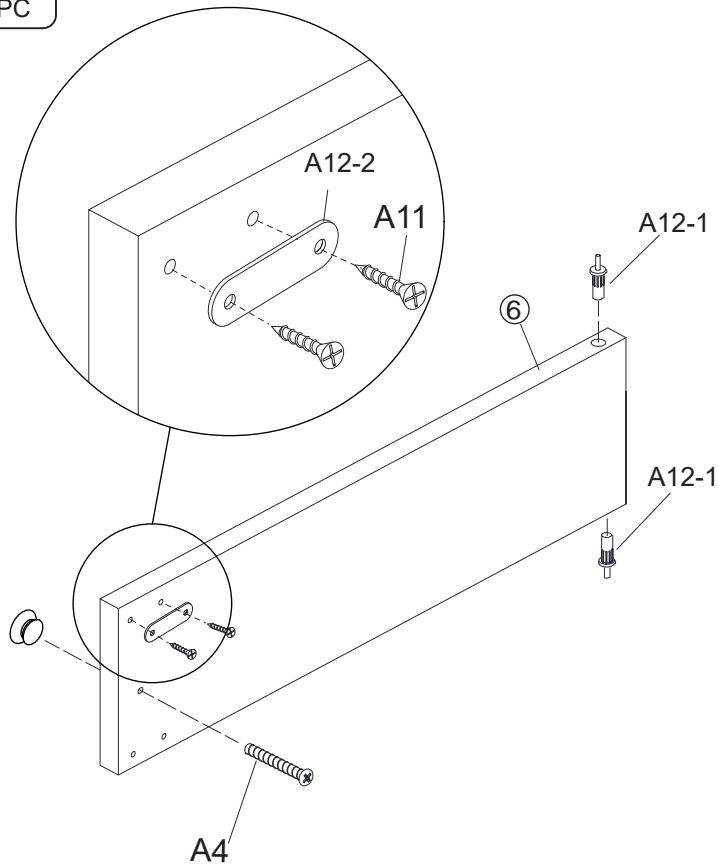
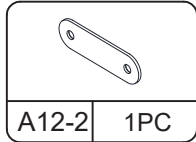
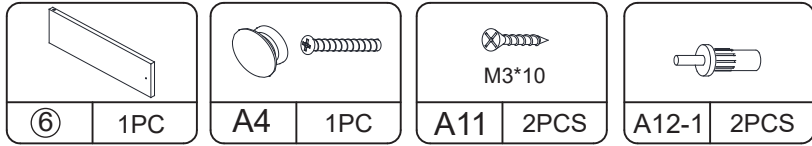

Note: According to your needs, the door can also be installed on the other side in the same way.

STEP 5

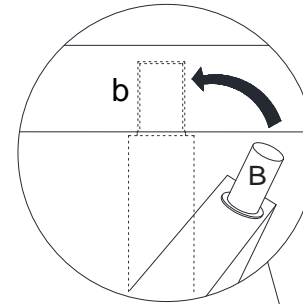

Insert (C) into the hole (c)
Tilt the door panel to place it under the top panel
Move to the left until (B) goes into the hole (b)

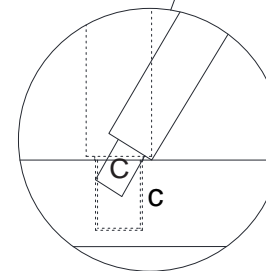
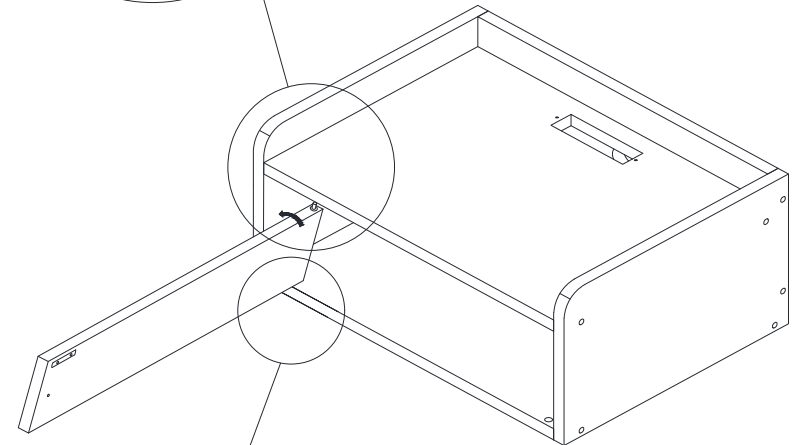

The letters (B, b, C, c) marked in the picture are just for clearer installation

Note: According to your needs, the door can also be installed on the other side in the same way.

PRODUCT ASSEMBLY

PRODUCT ASSEMBLY

STEP 6

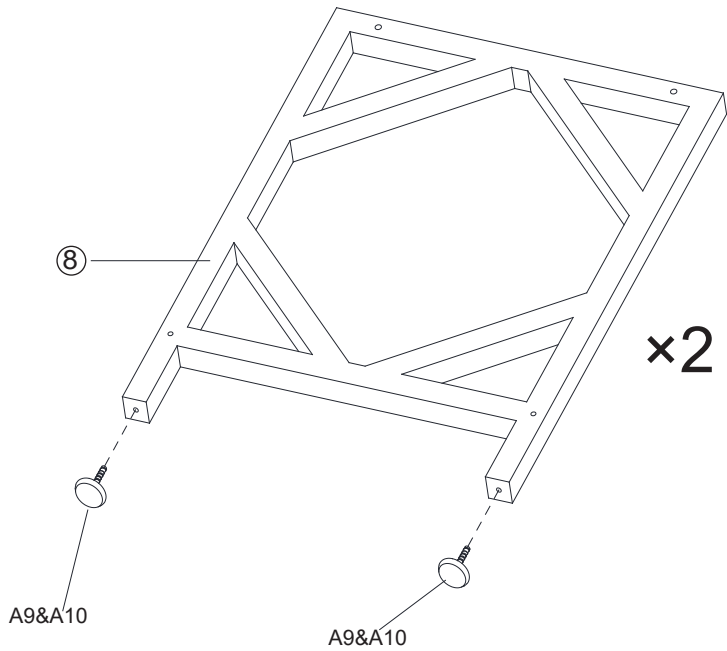

STEP 7

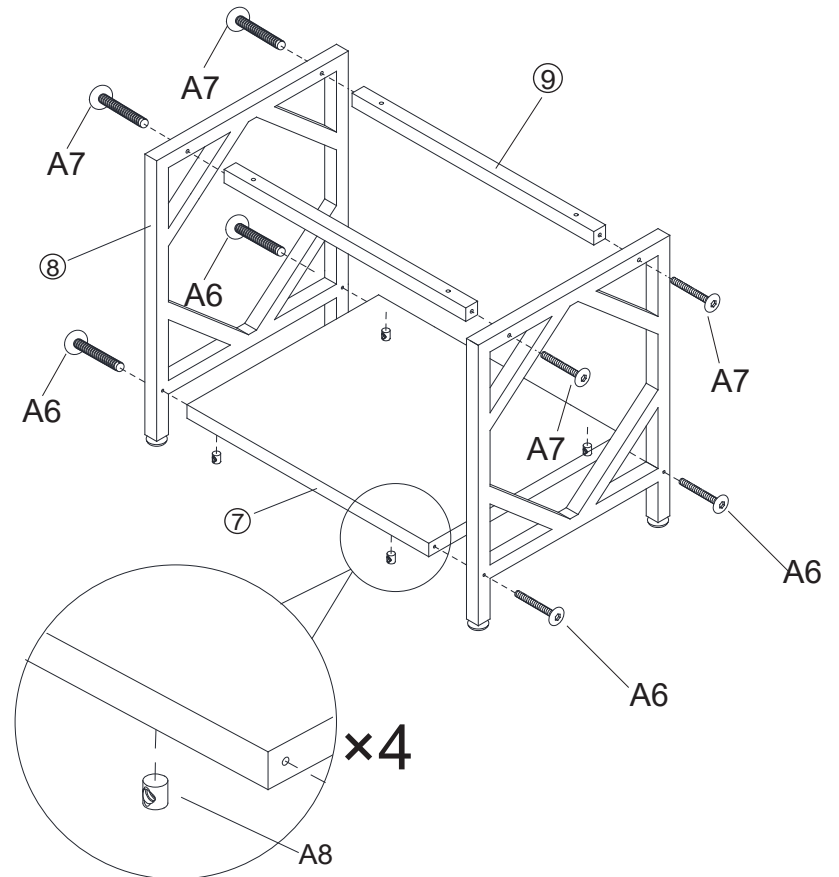
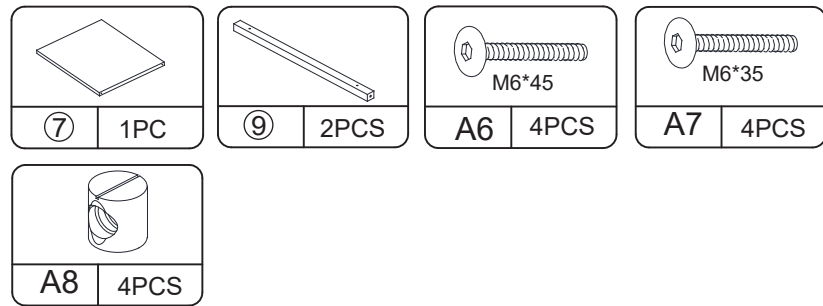

PRODUCT ASSEMBLY

STEP 8

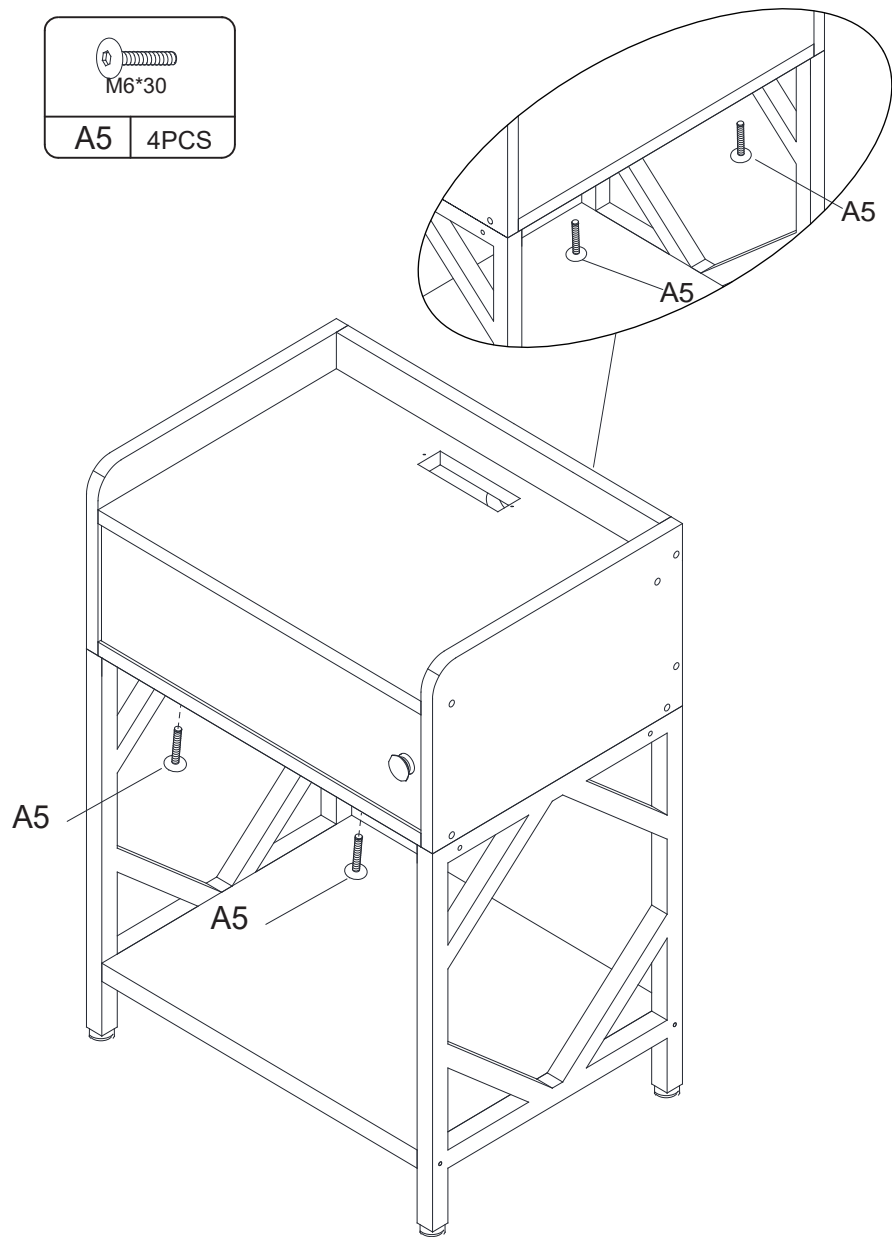
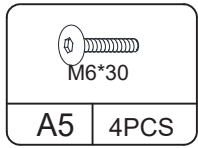

PRODUCT ASSEMBLY

STEP 9

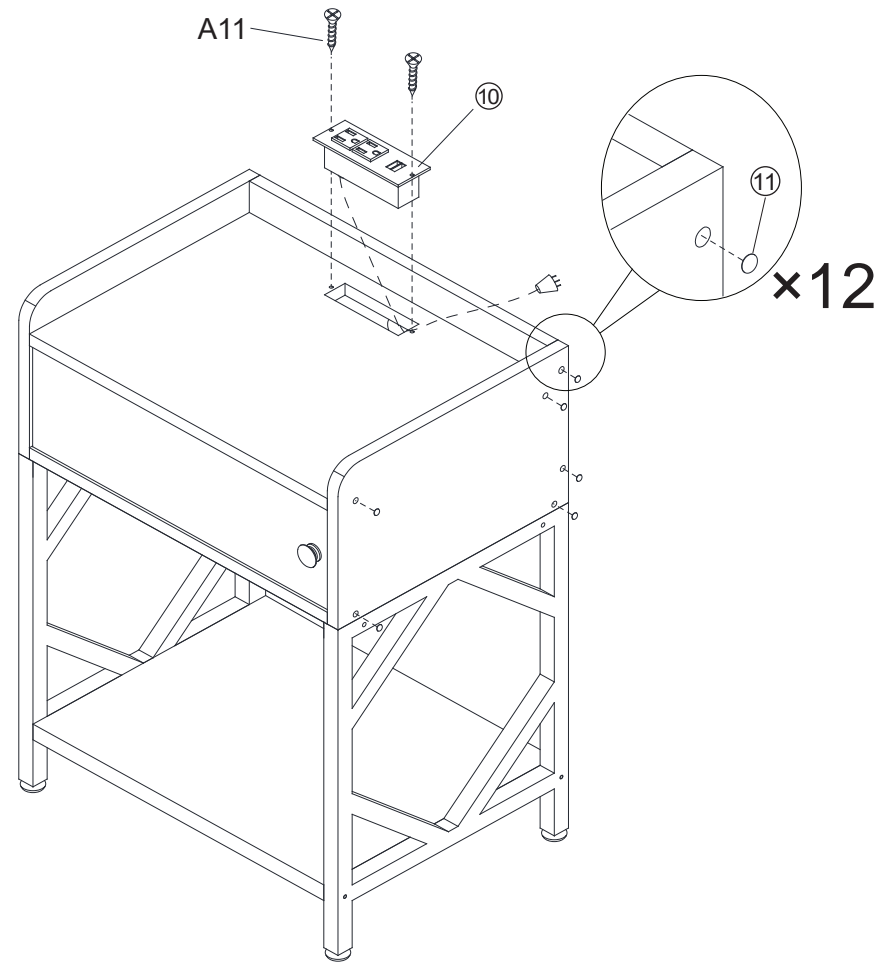
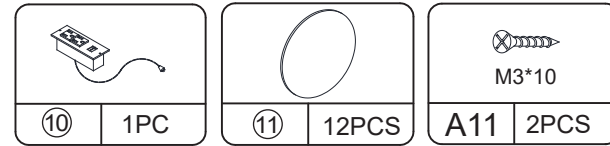

Repeat the above steps to start another assembly.