

# User Manual

# JAXPETY

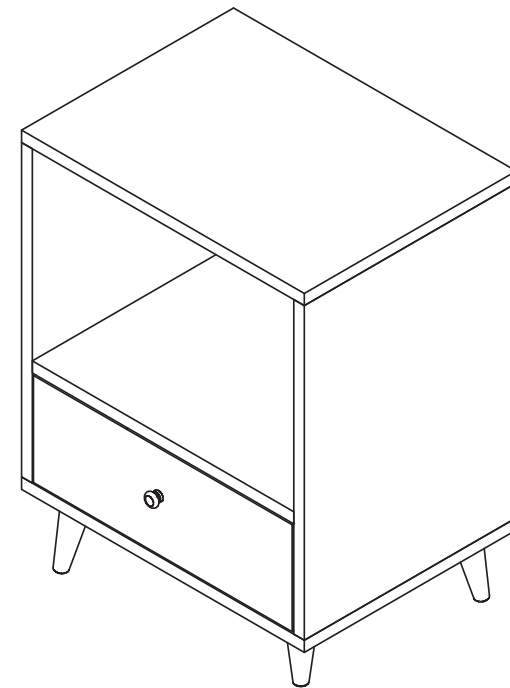

Model Number: HG61H0874  
HG61F0584  
HG61G0585

**JAXPETY**

# You need











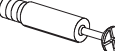

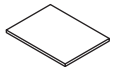
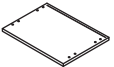

**1 Tools required**

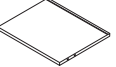
A Phillips head screwdriver is required for the assembly of this product. (not included)

Power tools should not be used to assemble this product.

**2 1 person is needed**

# Hardware List

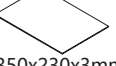
 Ø15x9mm A   16PCS	 Ø6x35mm B   16PCS	 Ø3x30mm C   4PCS	 Ø8x30mm D   12PCS
 Ø4x18mm E   1PC	 F   1PC	 400x300x15mm ①   1PC	 400x300x15mm ②   1PC
 400x300x15mm ③   1PC	 400x300x15mm ④   1PC	 370x300x15mm ⑤   1PC	 Ø35x100mm ⑥   4PCS
 375x235x3mm ⑦   1PC	 375x17x3mm ⑧   1PC	 365x160x12mm ⑨   1PC	 240x120x12mm ⑩   1PC
 240x120x12mm ⑪   1PC	 340x120x12mm ⑫   1PC	 350x230x3mm ⑬   1PC	

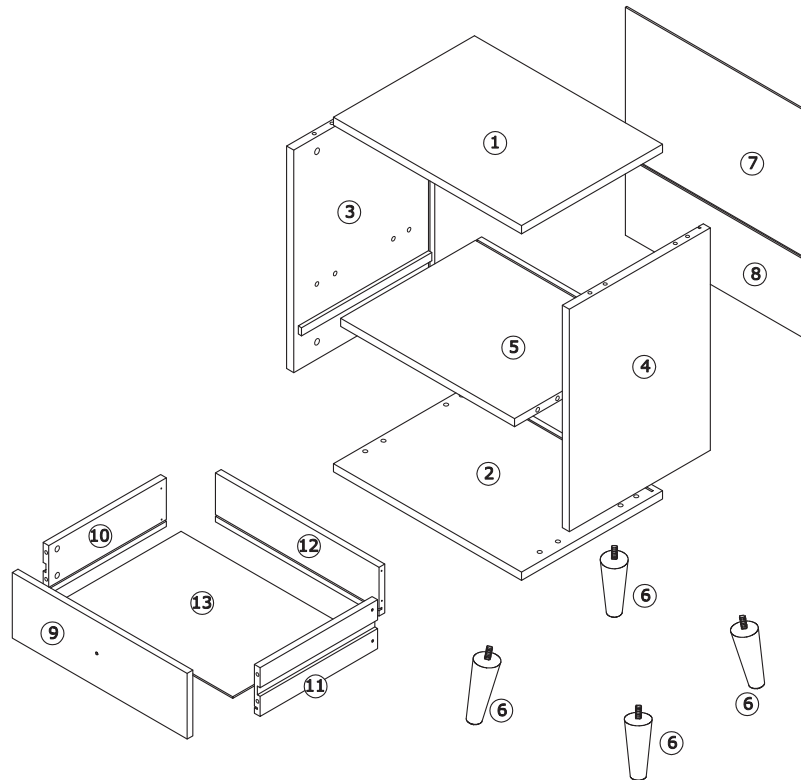

PRODUCT ASSEMBLY

PRODUCT ASSEMBLY

**!** Check the package contents before getting started !

**STEP 1**

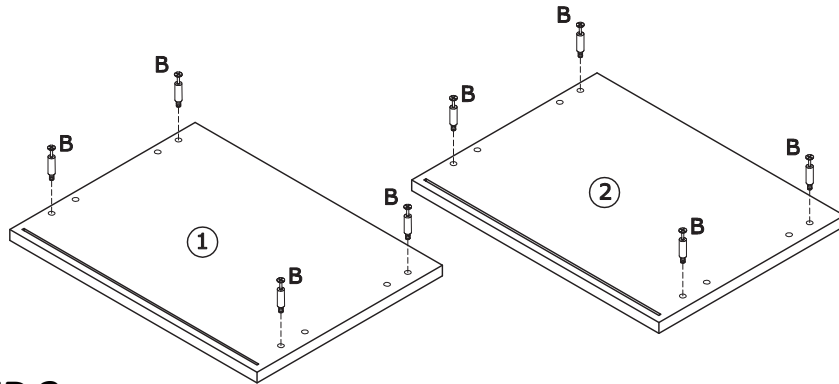
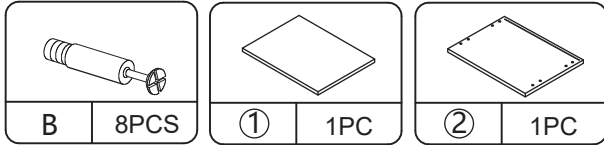

**STEP 3**

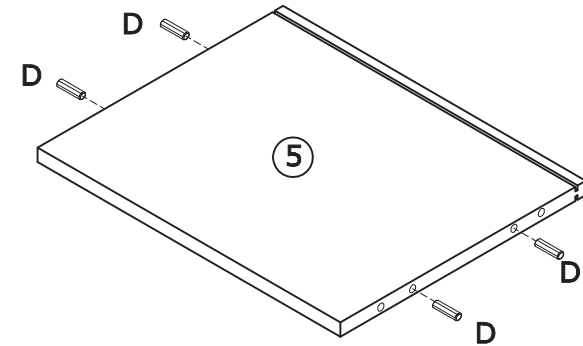
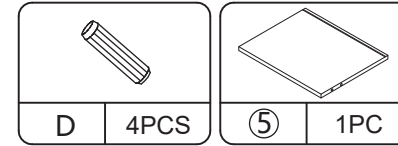

**STEP 4**

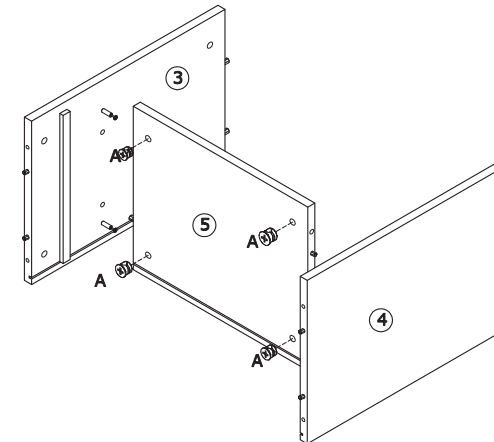
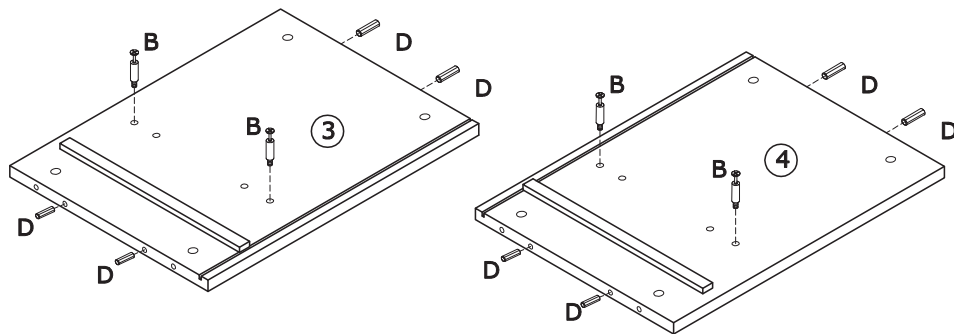
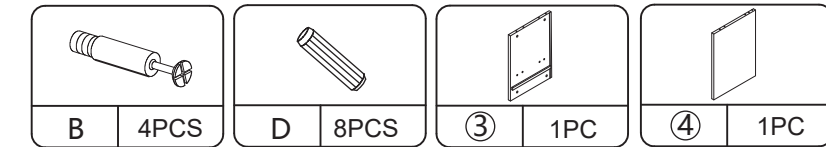
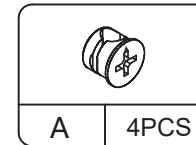

PRODUCT ASSEMBLY

STEP 5

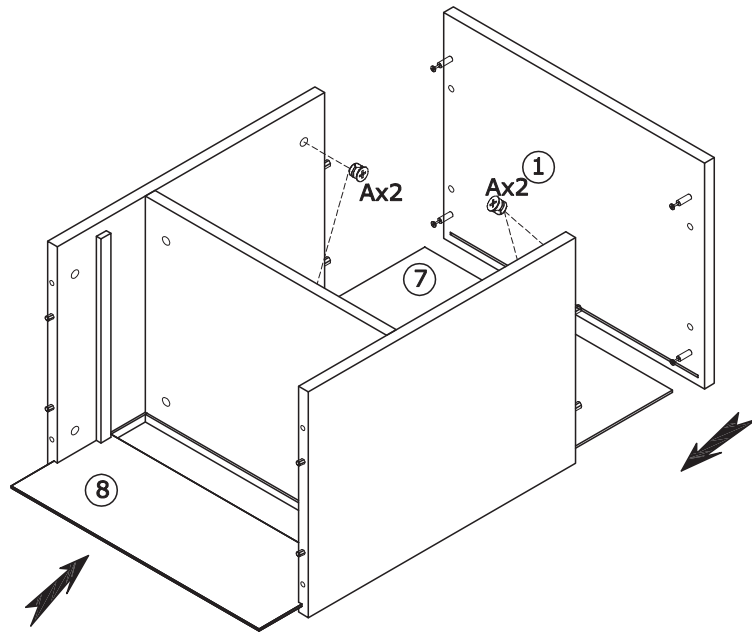
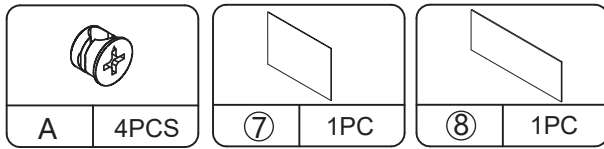

PRODUCT ASSEMBLY

STEP 6

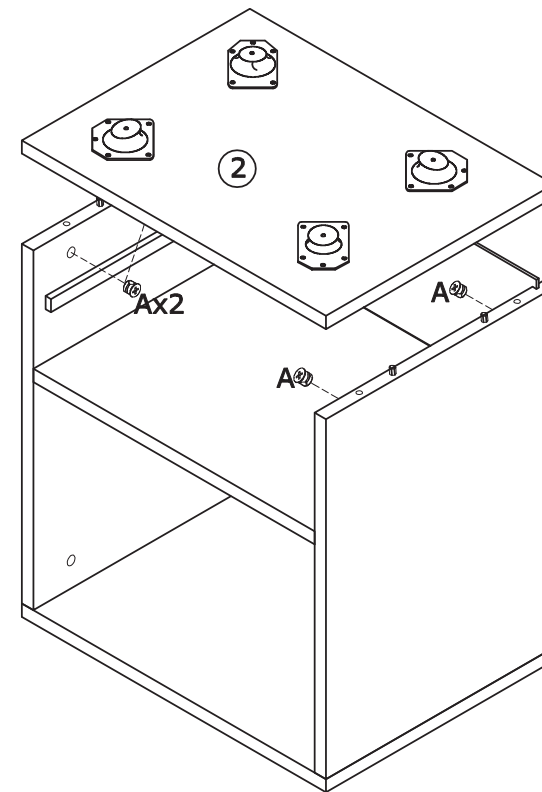
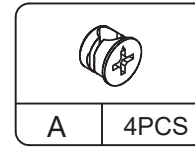

PRODUCT ASSEMBLY

STEP 7

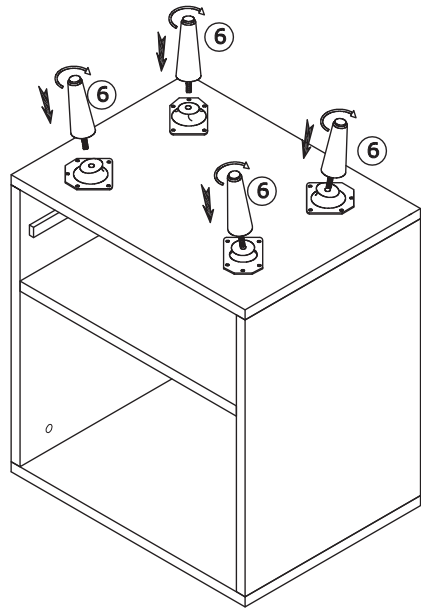
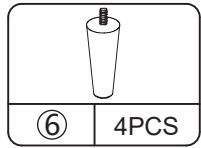

STEP 8

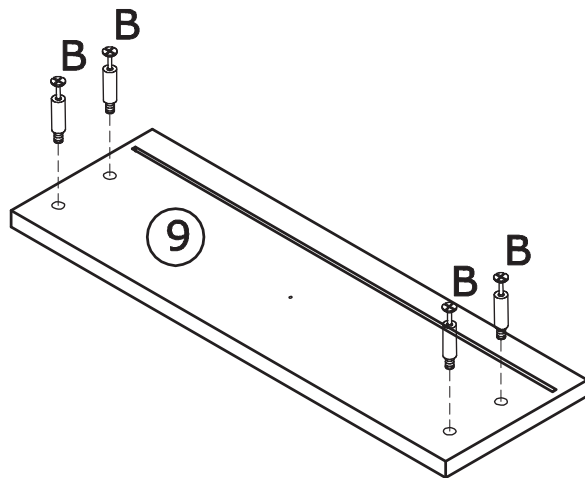
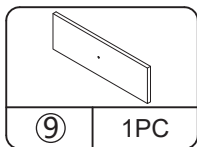
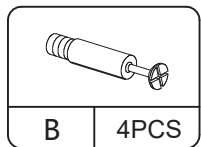

PRODUCT ASSEMBLY

STEP 9

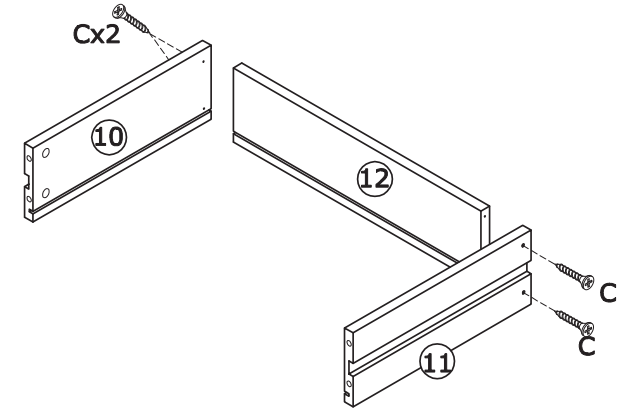
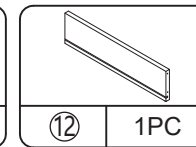
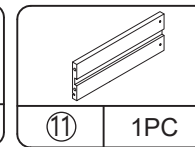
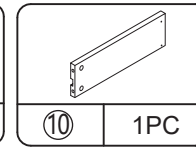
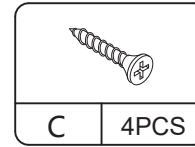

STEP 10

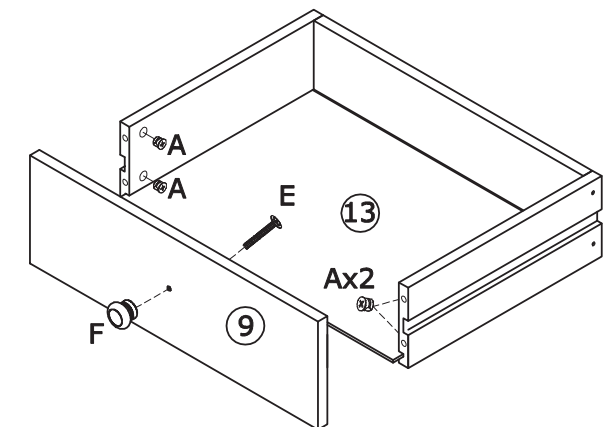
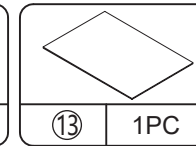
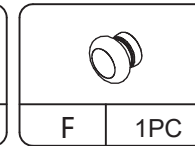
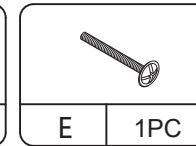
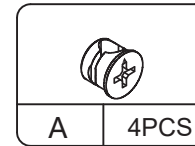

STEP 11

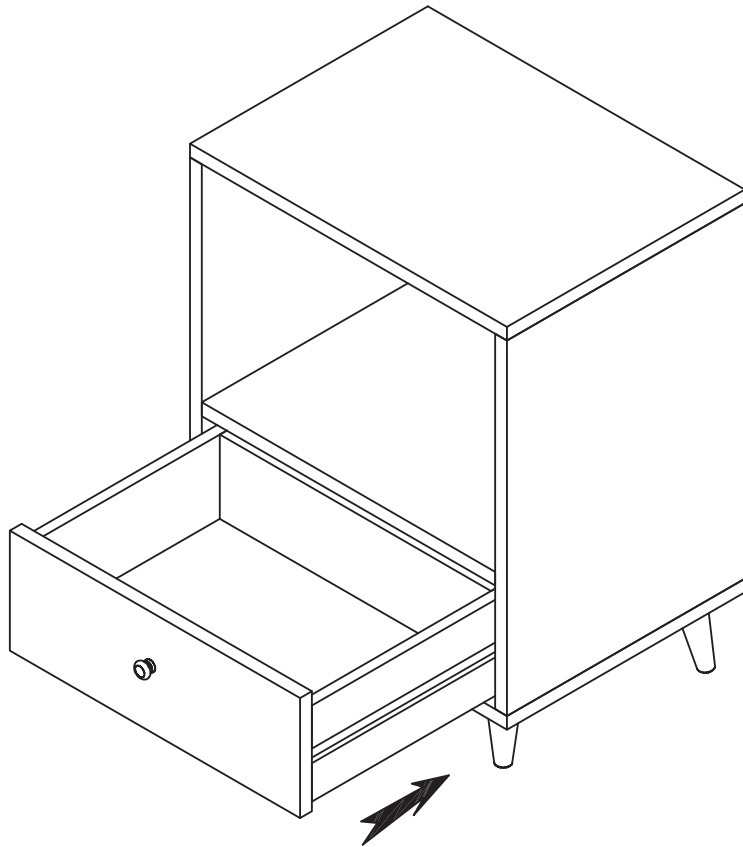

STEP 12

