

User Manual

JAXPETY

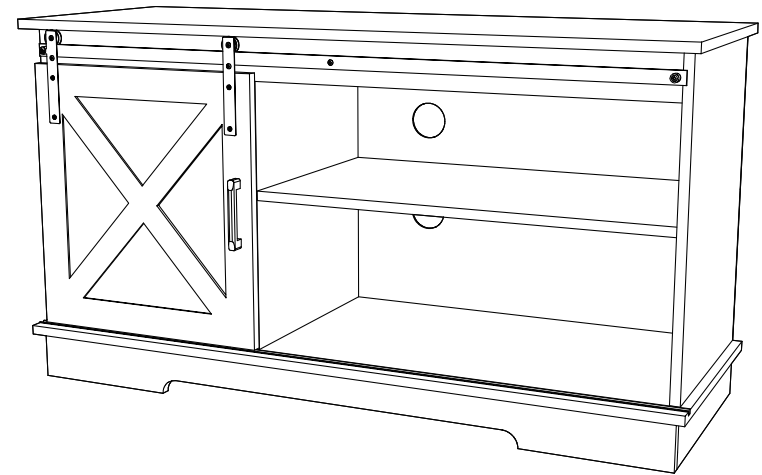

Scan ! To find more surprise!

You need

① Tools required

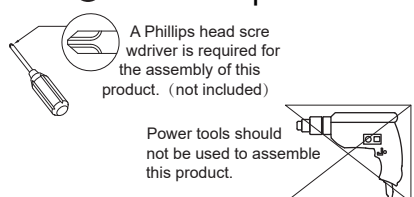

A Phillips head screwdriver is required for the assembly of this product. (not included)

Power tools should not be used to assemble this product.







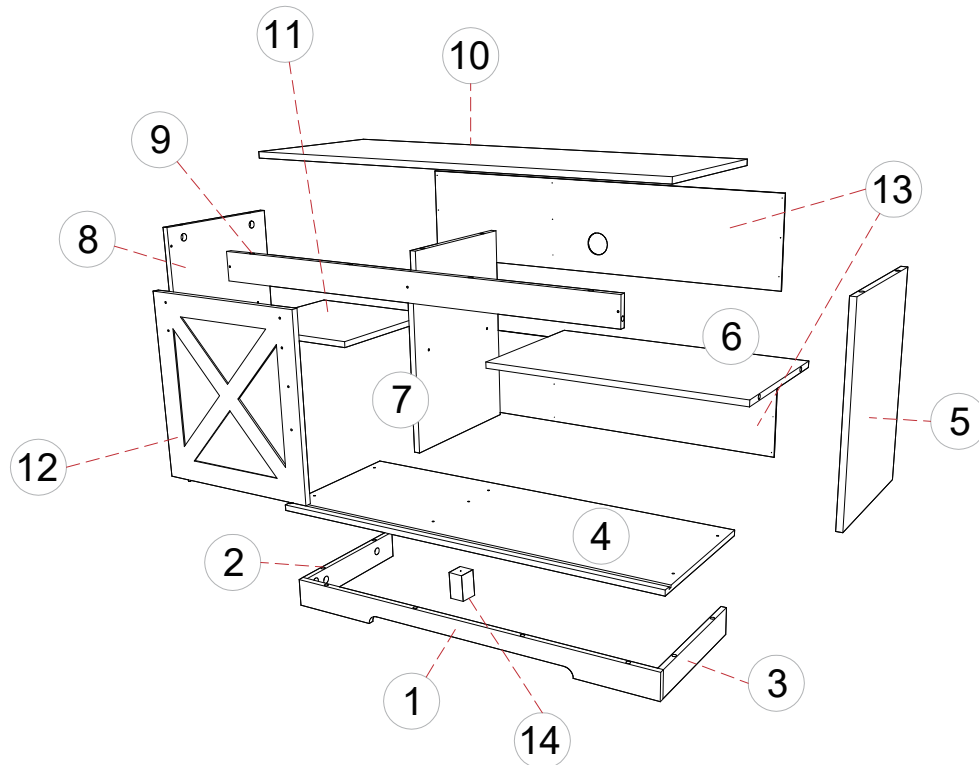

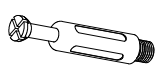

② 2 persons are needed



Technical Specifications	
Brand	JAXPETY
Size	1100*400*600mm

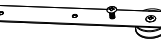

Hardware List

			
A1 34PCS	A2 34PCS	C 4PCS	D 3PCS
			
E 5PCS	F 1PC	G 1PC	H 2PCS
			
I 4PCS	J 2PCS	K 1PC	L 18PCS

PRODUCT ASSEMBLY

⚠ Check the package contents before getting started !

STEP 1

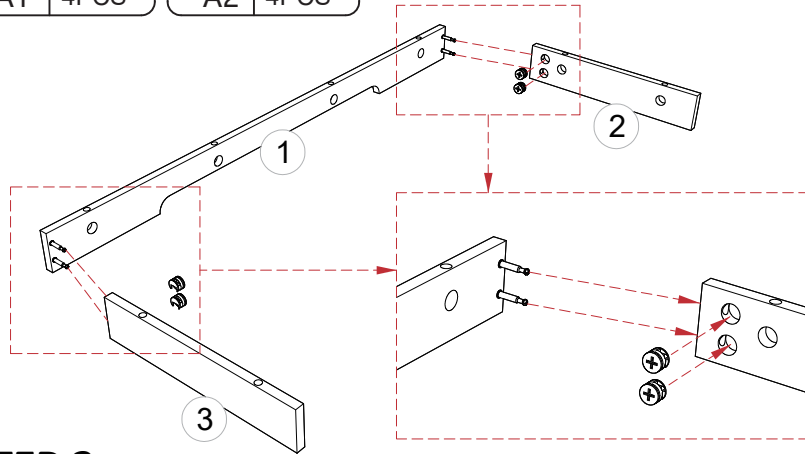
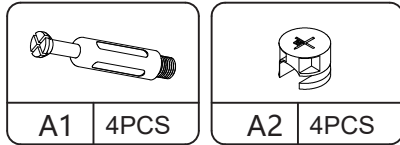

STEP 2

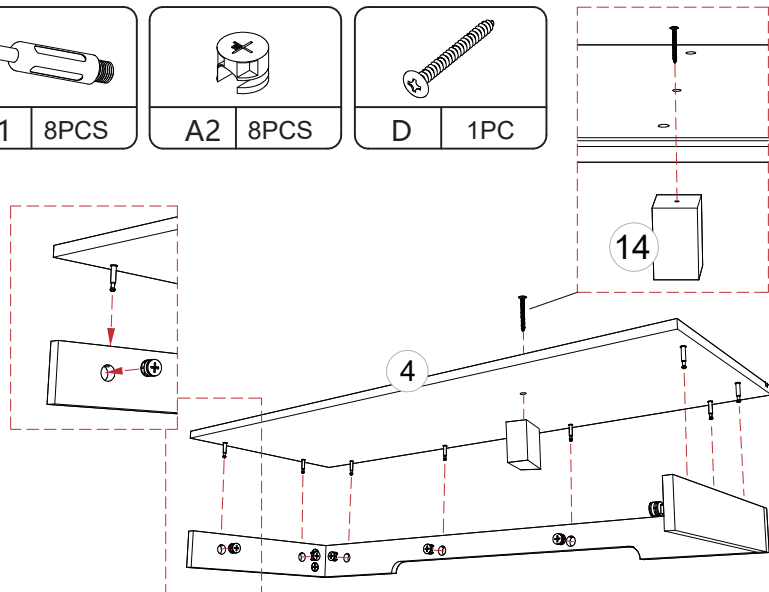
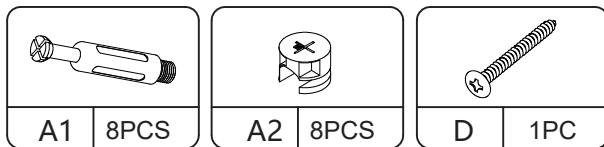

PRODUCT ASSEMBLY

STEP 3

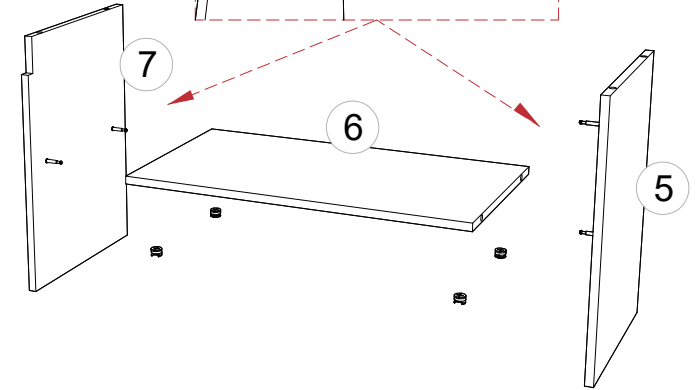
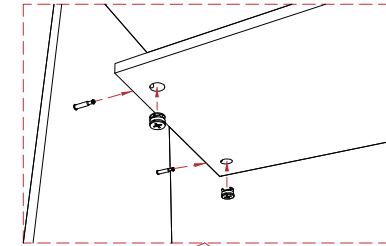
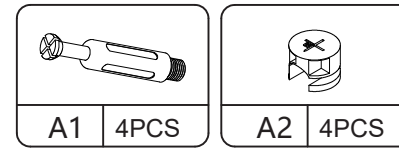

STEP 4

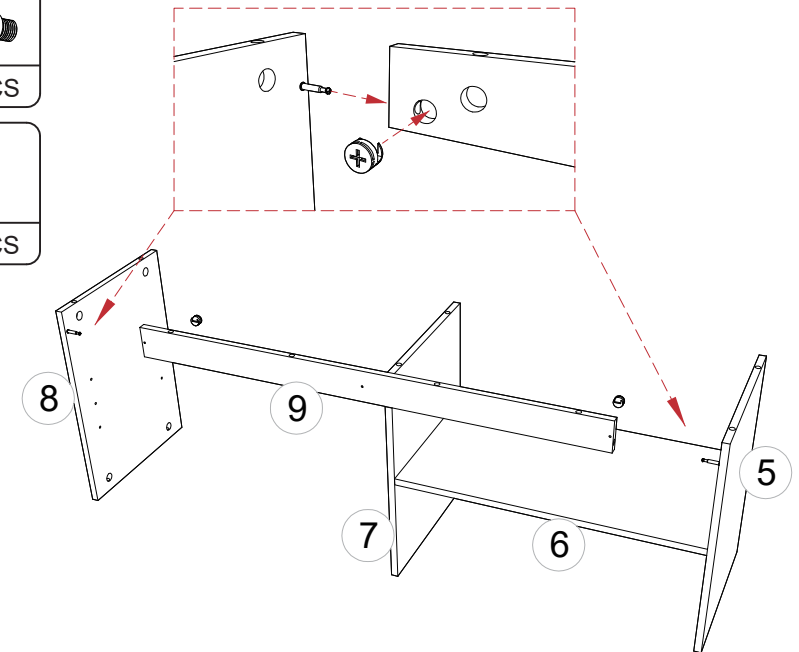
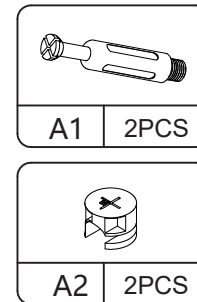

PRODUCT ASSEMBLY

STEP 5

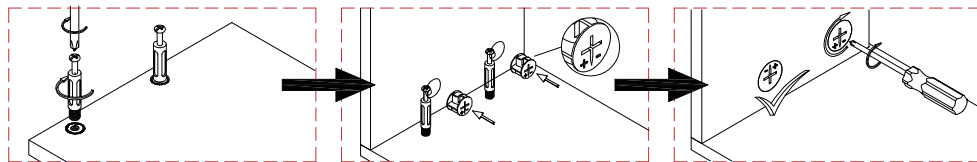
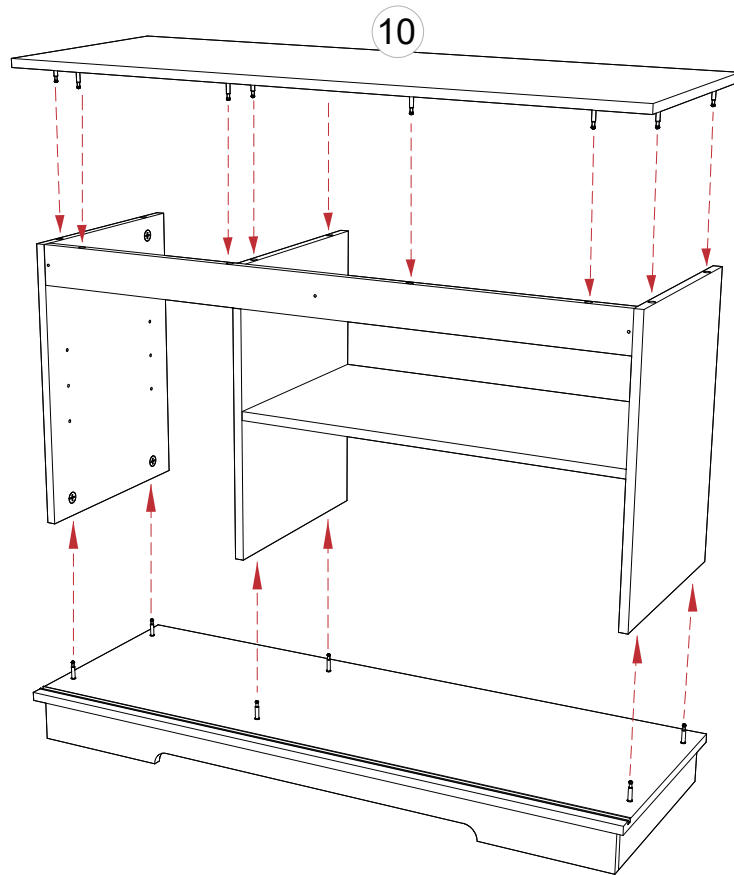
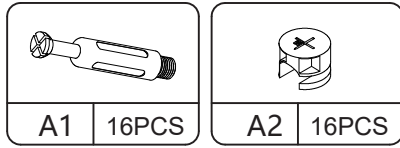

PRODUCT ASSEMBLY

STEP 6

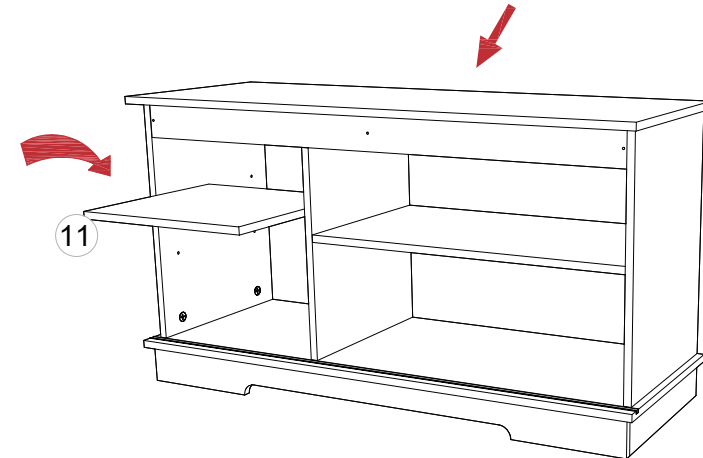
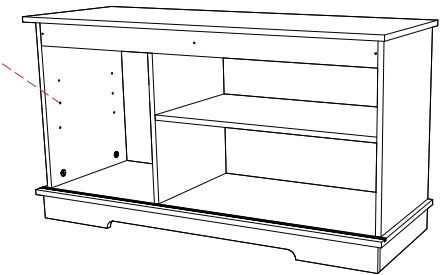
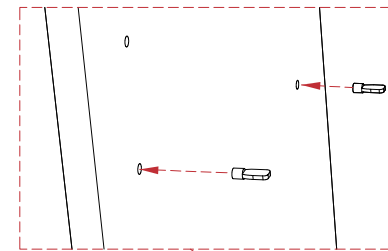
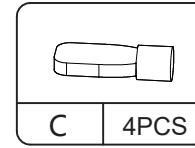

STEP 7

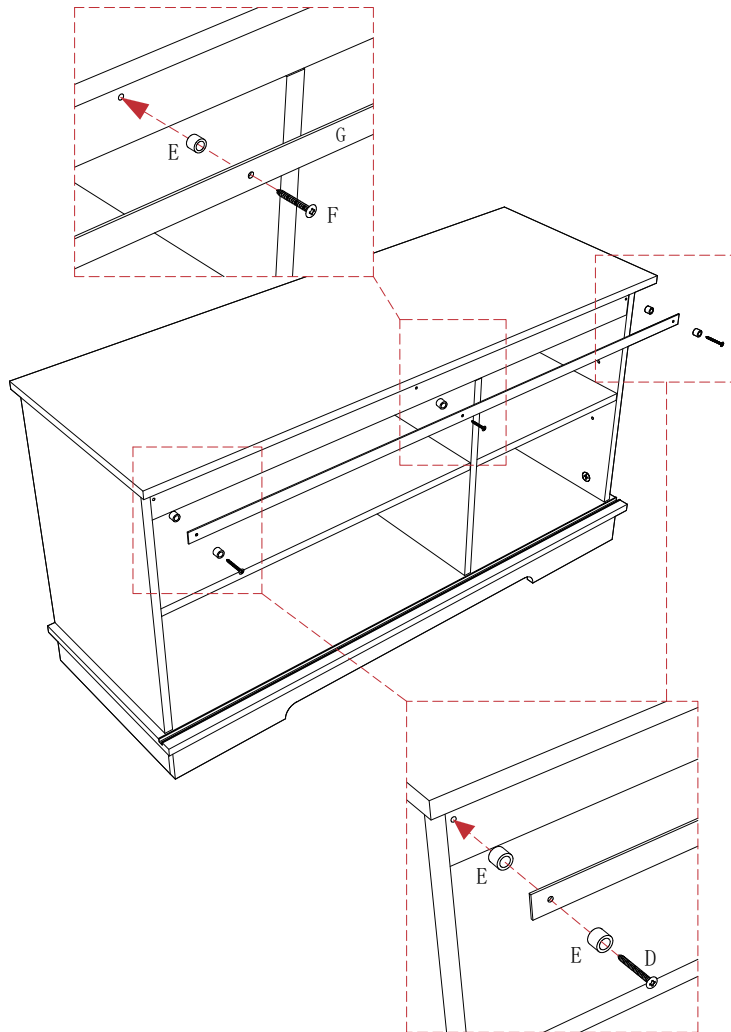
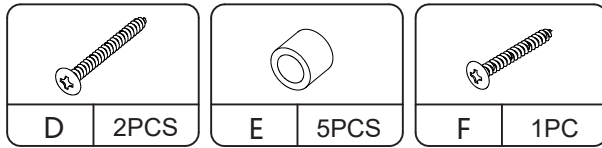

STEP 8

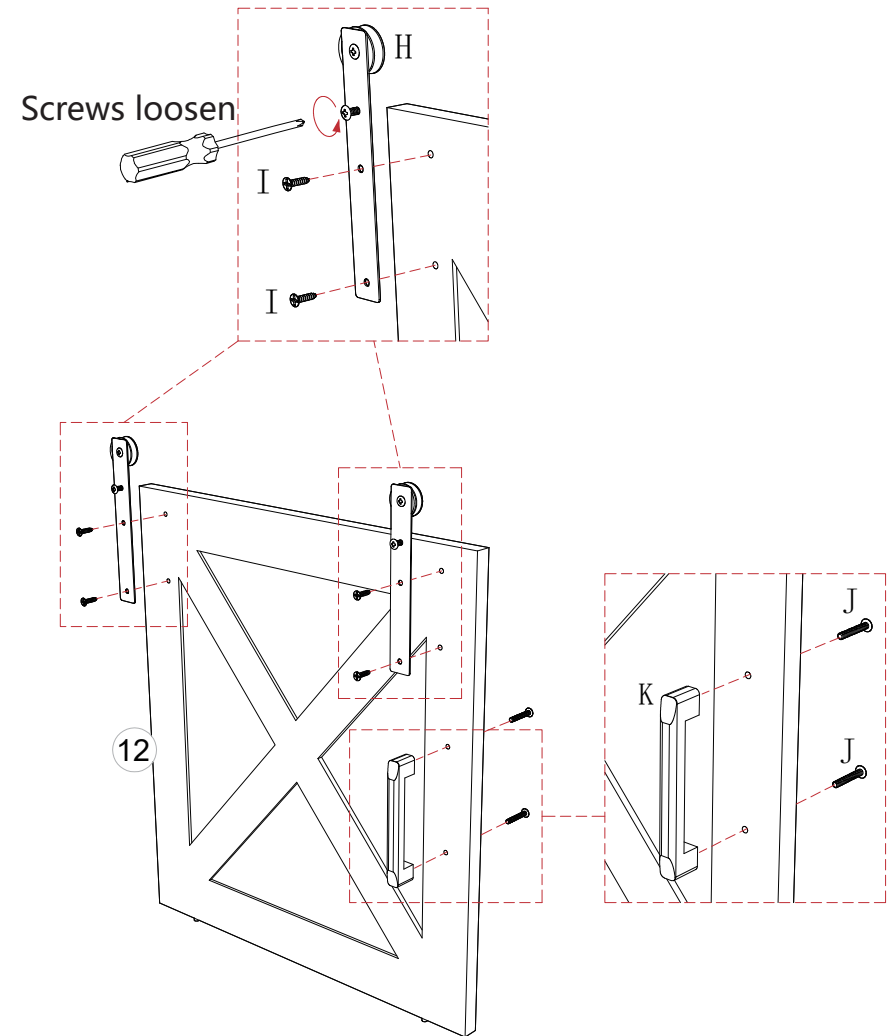
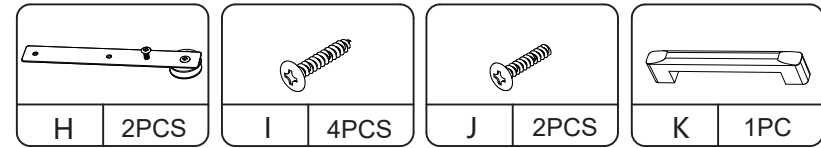

STEP 9

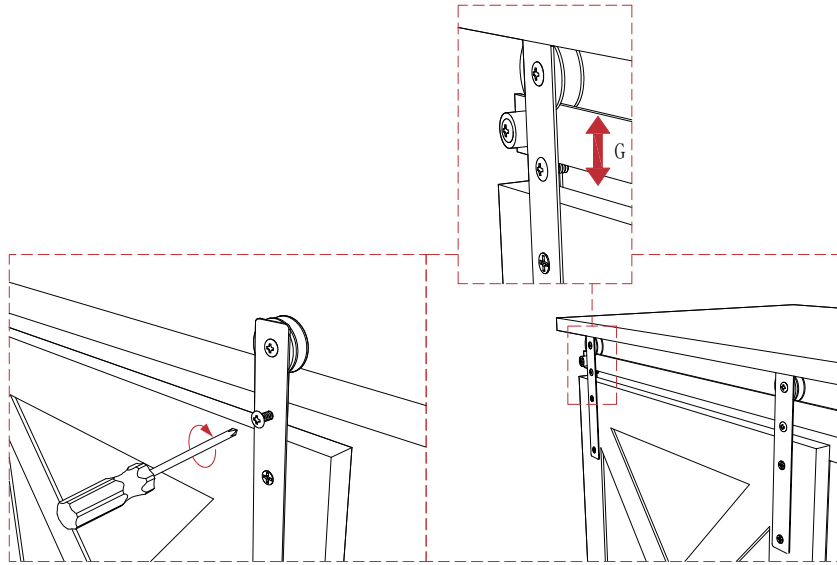

tighten the screw

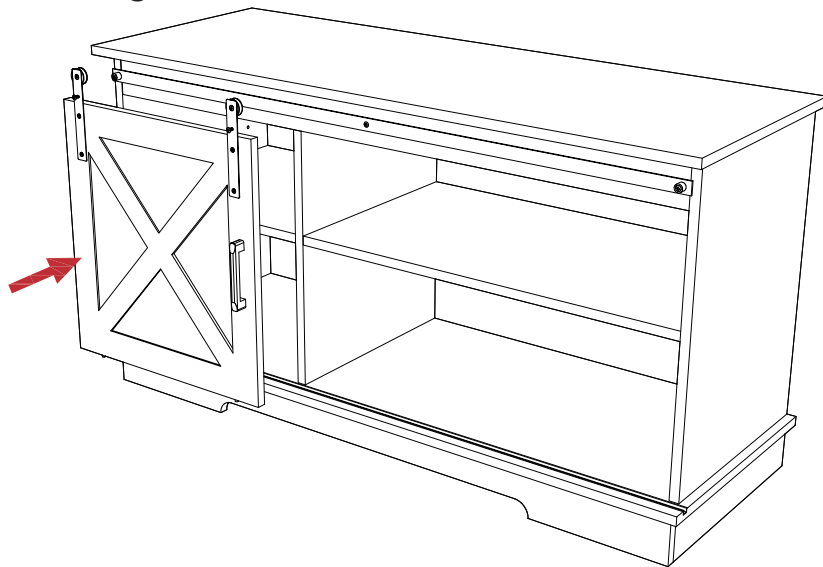

STEP 10

