

## User Manual

# JAXPETY

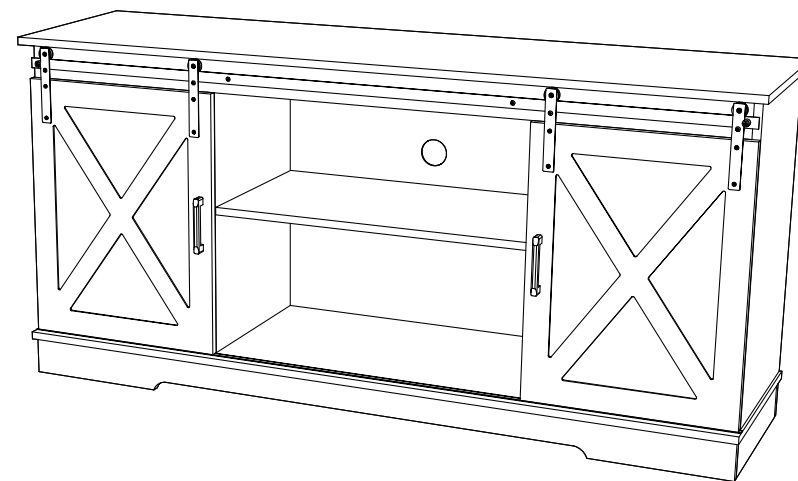

Scan ! To find more surprise!



## You need

**① Tools required**

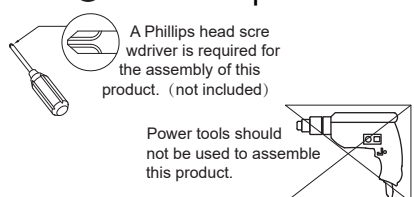

A Phillips head screwdriver is required for the assembly of this product. (not included)

Power tools should not be used to assemble this product.







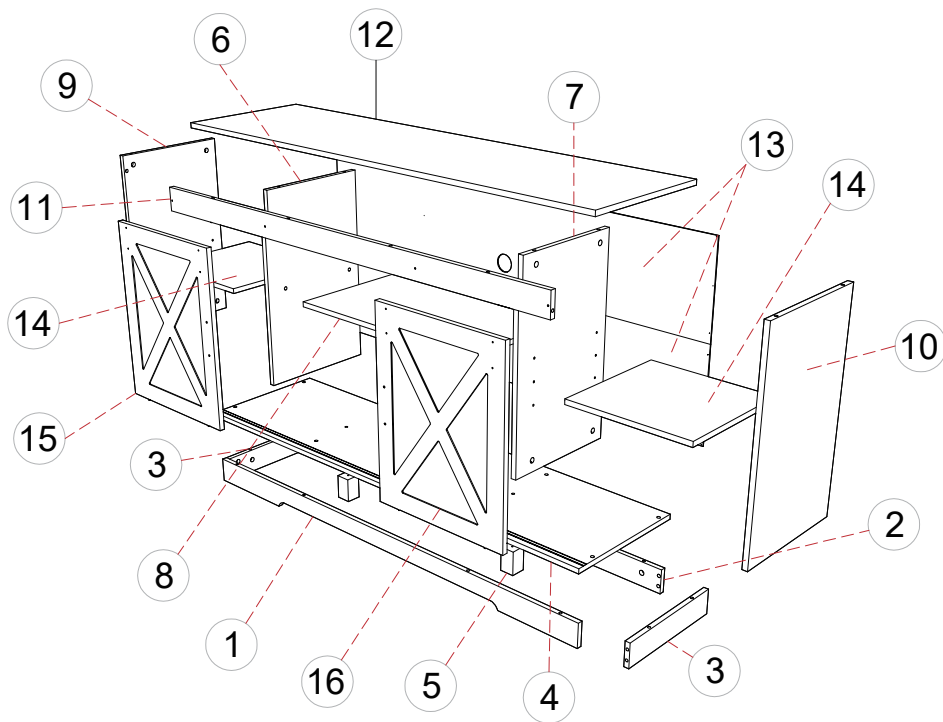



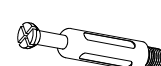

**② 2 persons are needed**

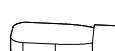

Technical Specifications	
Brand	JAXPETY
Size	1470*400*700mm



## Hardware List

			
A1   46PCS	A2   46PCS	B   2PCS	C   24PCS
			
D   8PCS	E   2PCS	F   6PCS	G   2PCS
			
H   1PC	I   4PCS	J   8PCS	K   4PCS
			
L   2PCS			

PRODUCT ASSEMBLY

⚠ Check the package contents before getting started!

STEP 1

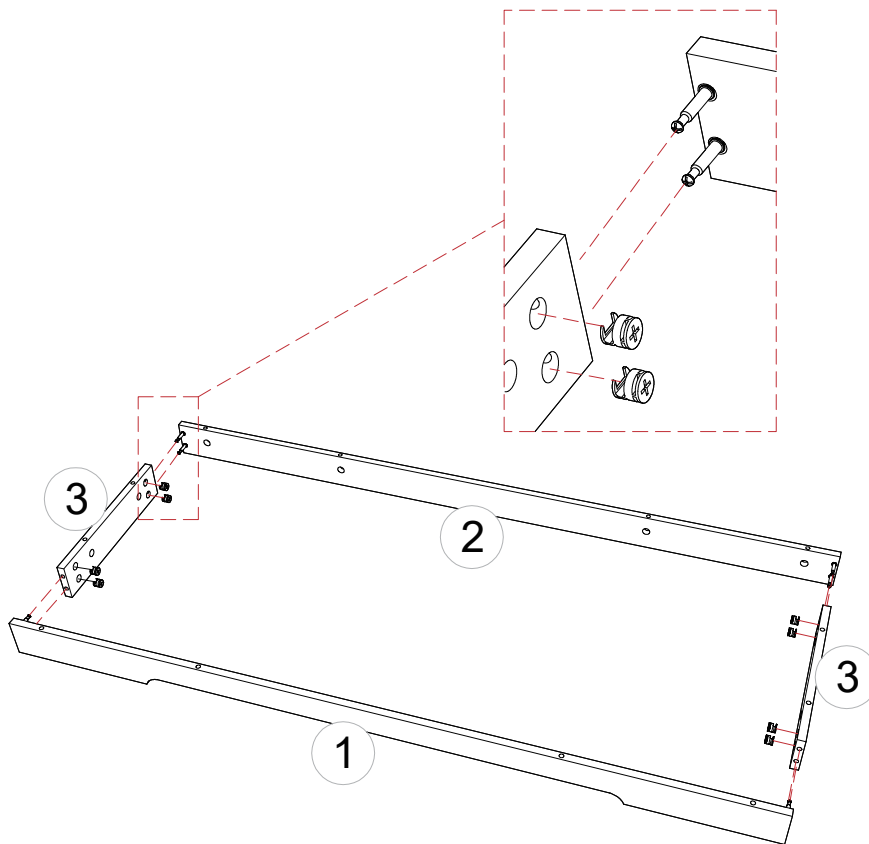
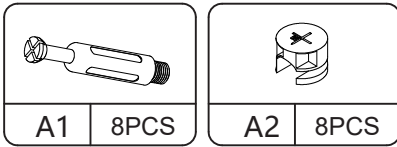

PRODUCT ASSEMBLY

STEP 2

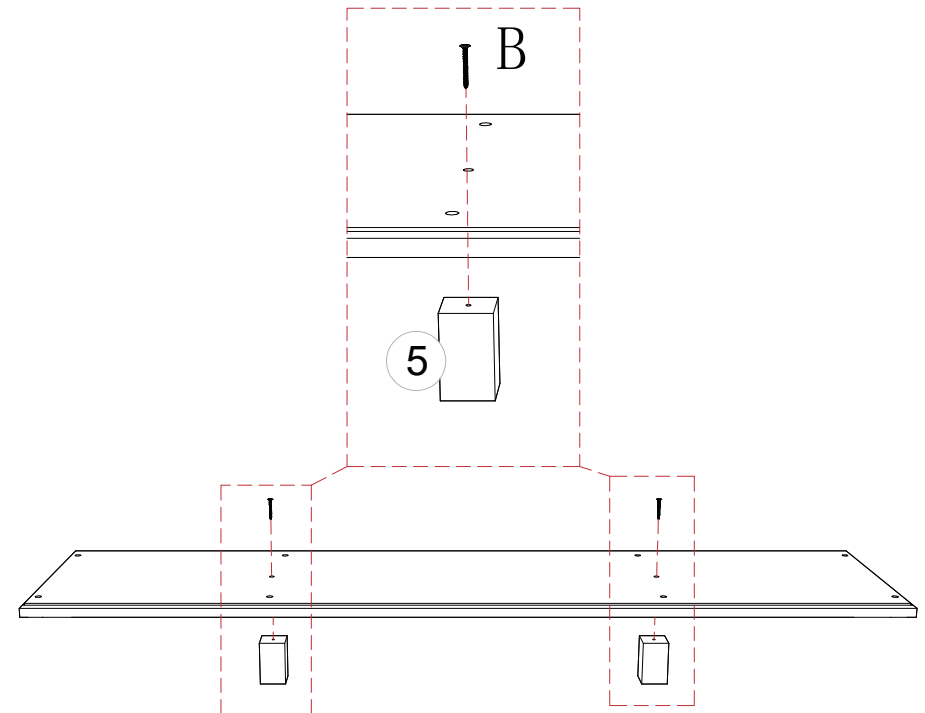
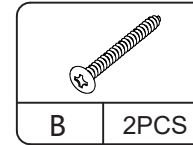

PRODUCT ASSEMBLY

STEP 3

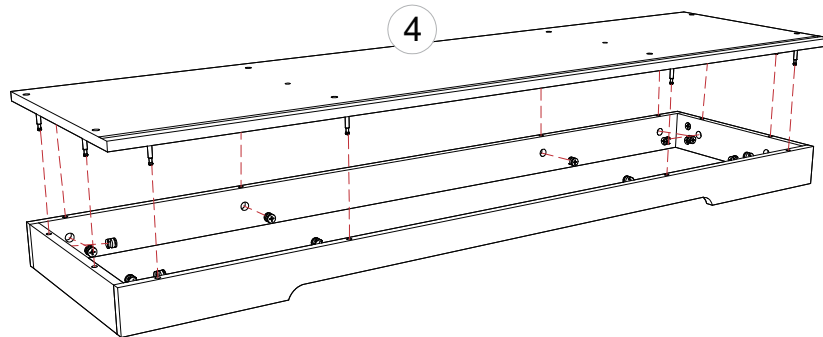
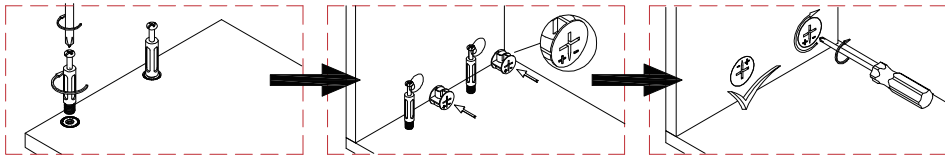
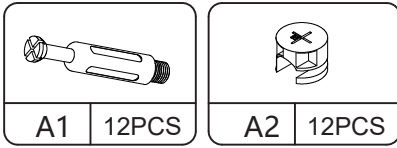

PRODUCT ASSEMBLY

STEP 4

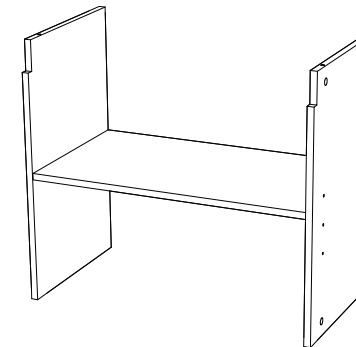
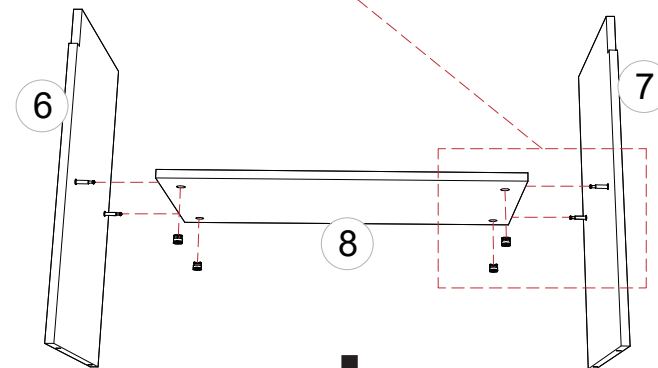
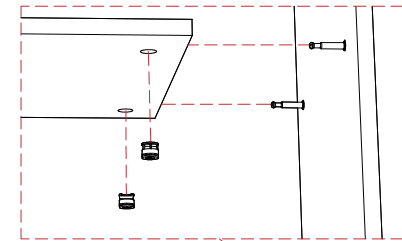
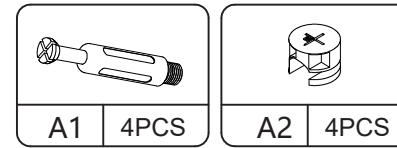

### STEP 5

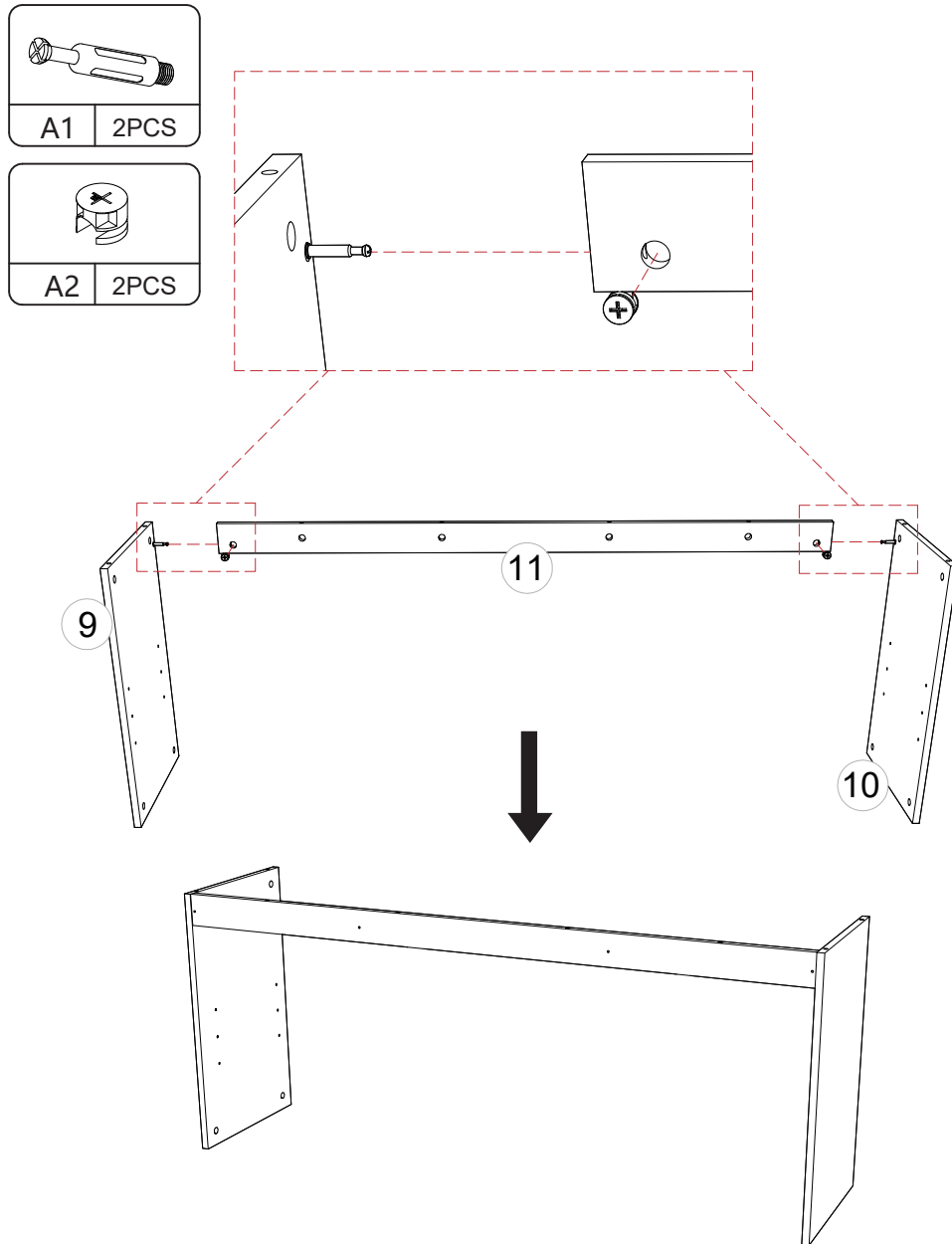

### STEP 6

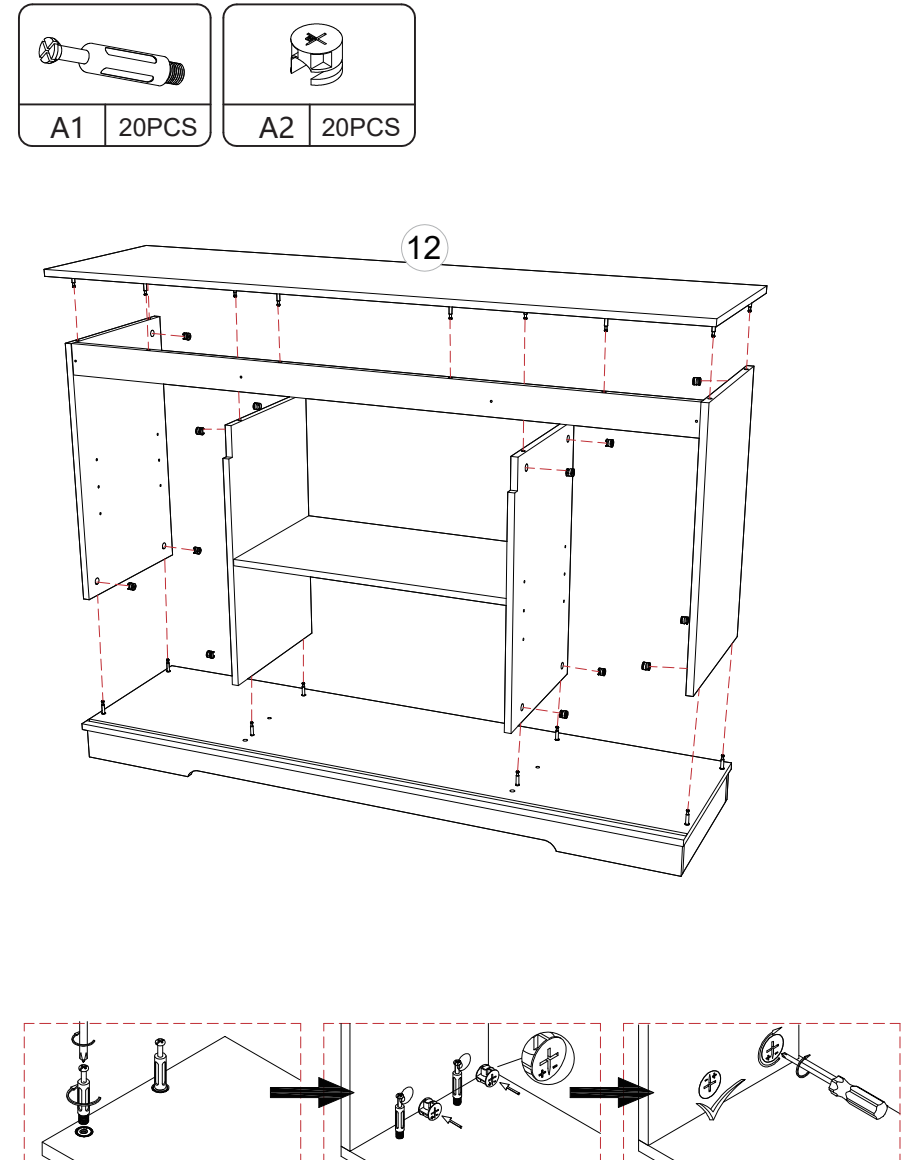

### STEP 7

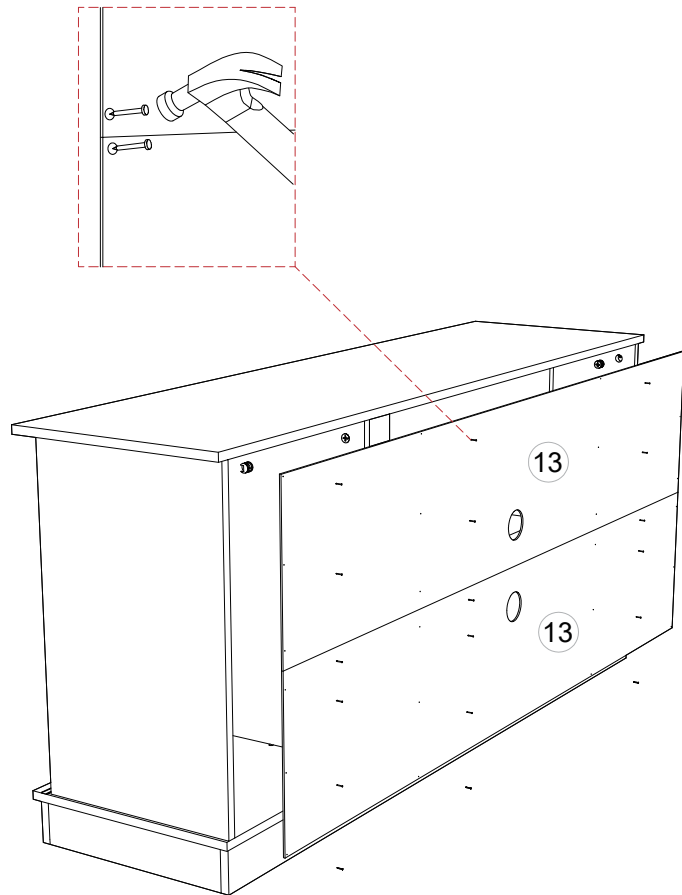
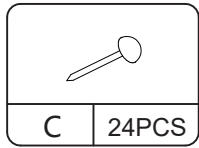

### STEP 8

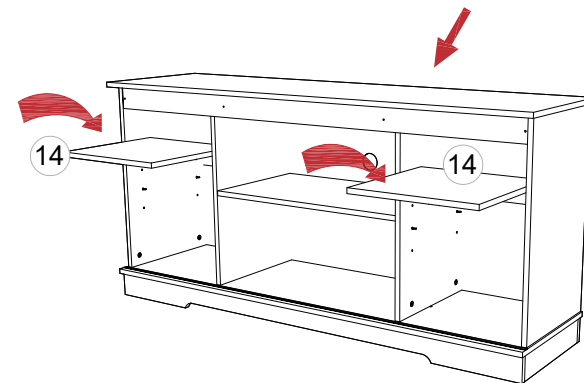
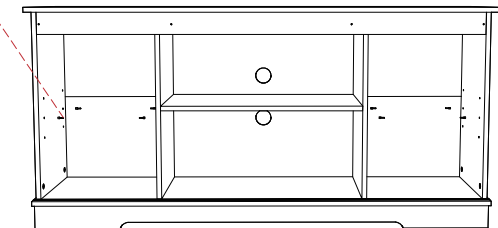
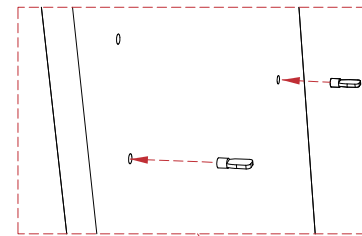
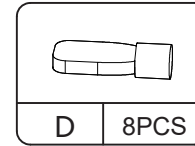

**STEP 9**

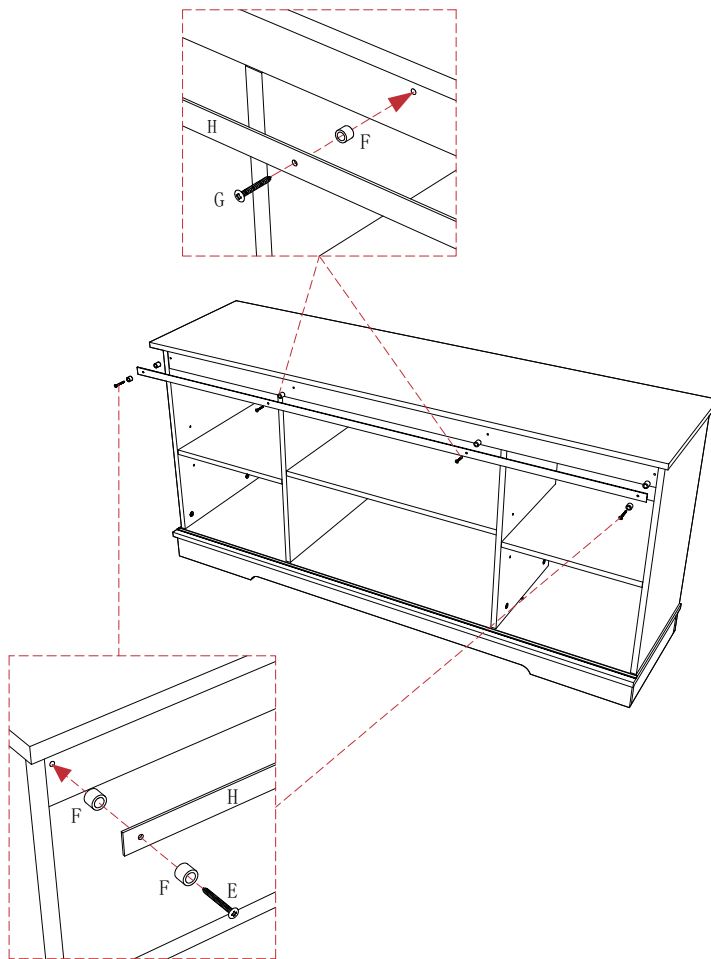
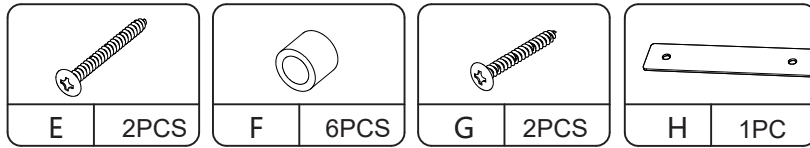

**STEP 10**

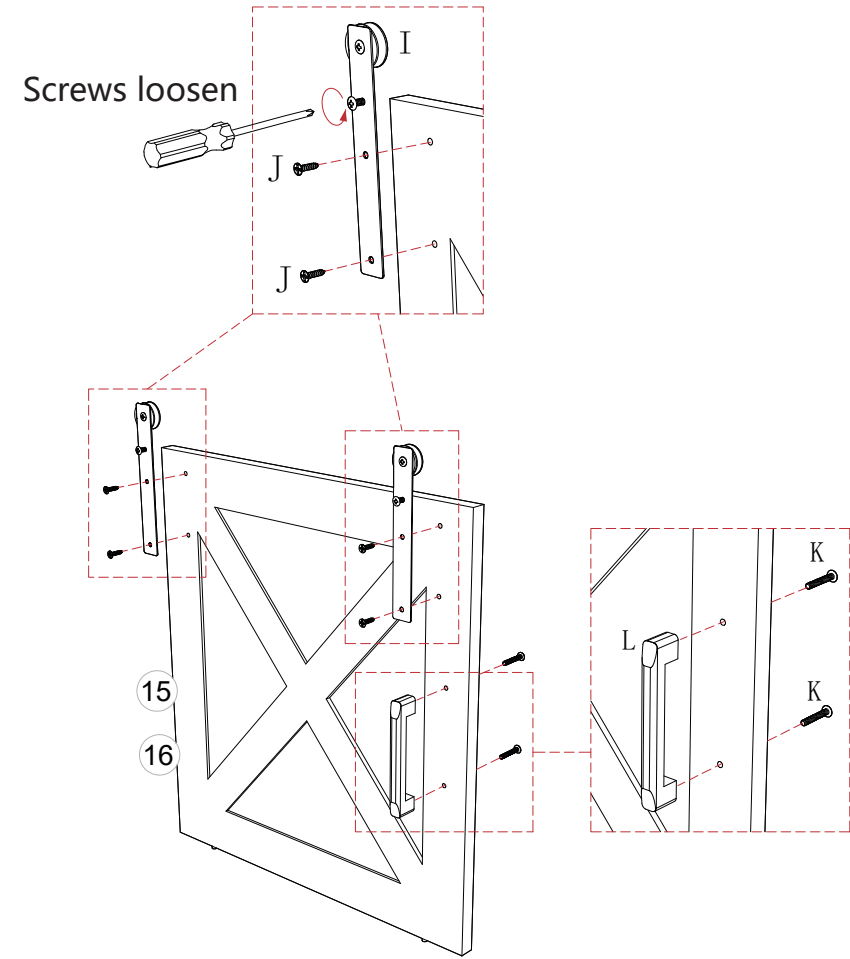
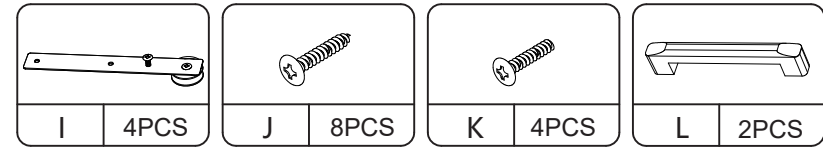

STEP 11

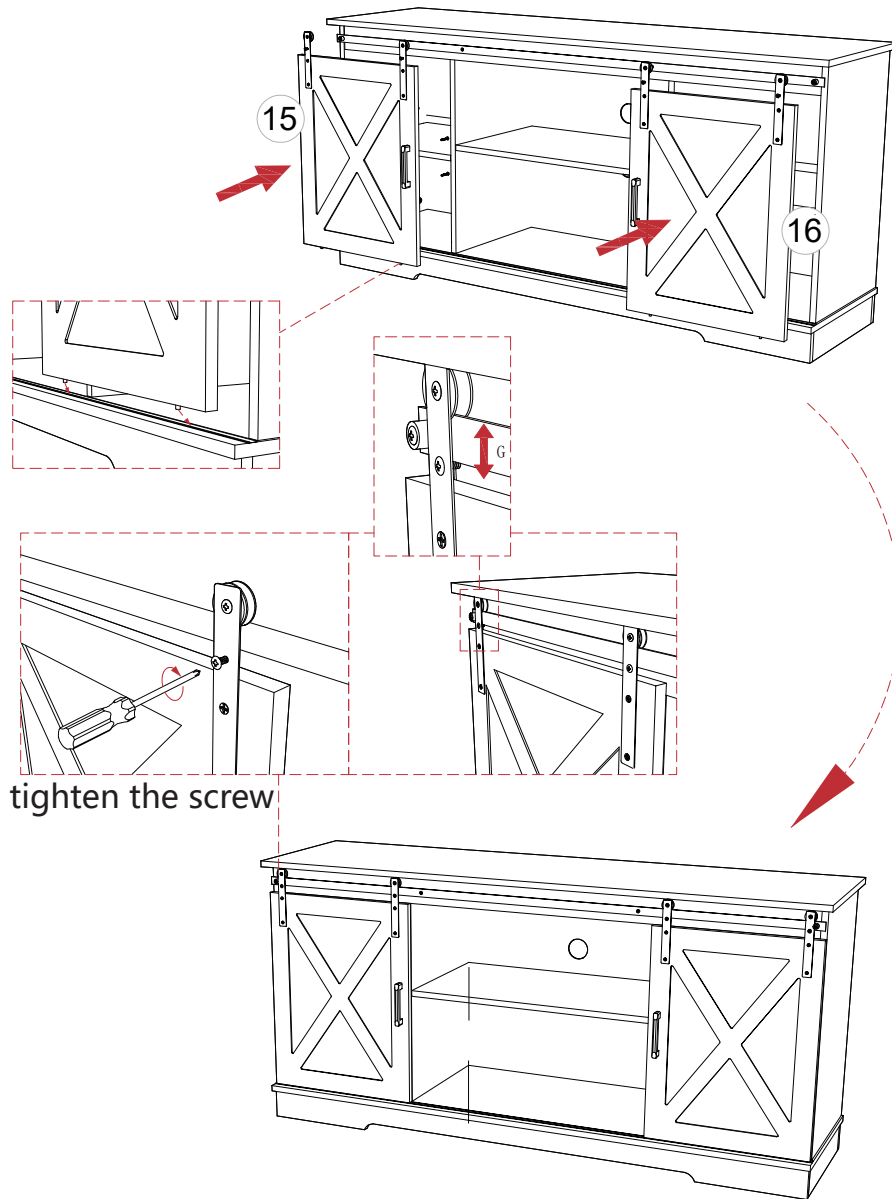

STEP 12

