

User Manual

JAXPETY

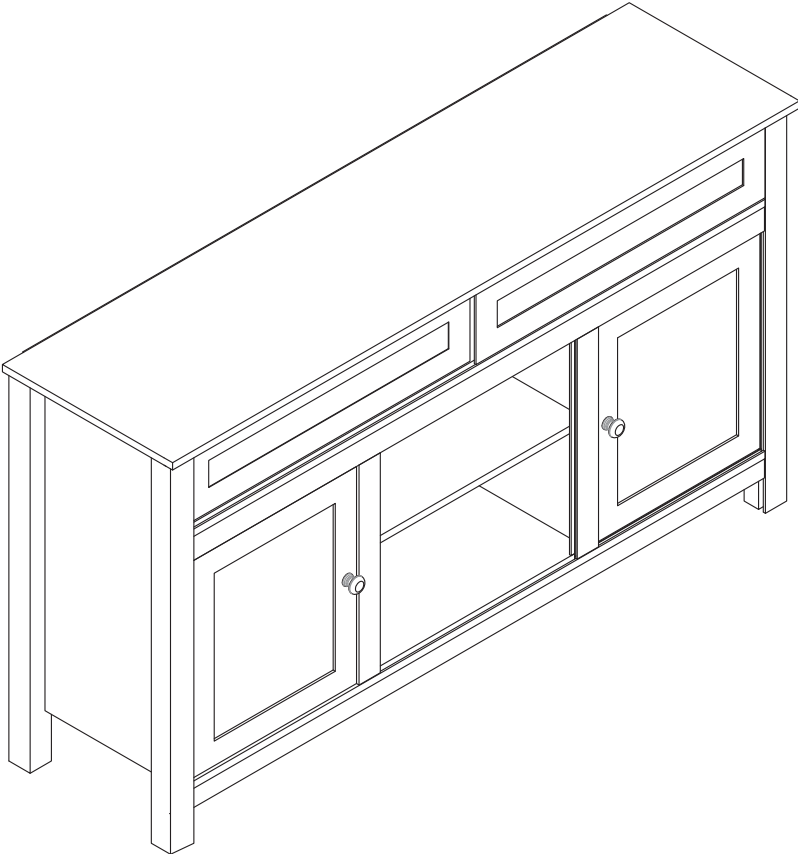

You need

1 Tools required

A Phillips head screwdriver is required for the assembly of this product. (not included)

Power tools should not be used to assemble this product.

2 1 person is needed

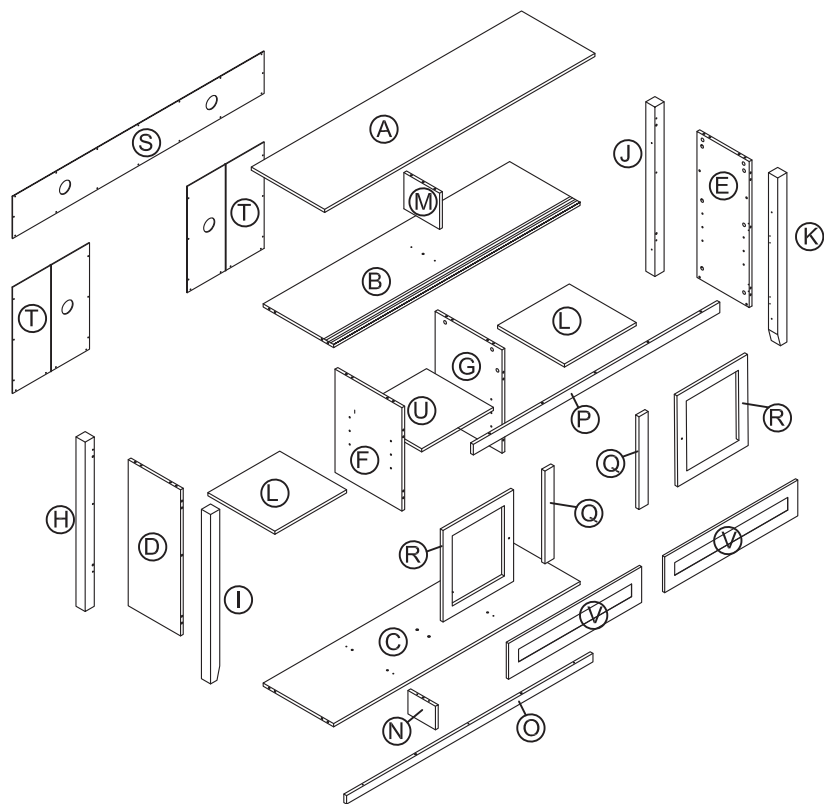





PRODUCT ASSEMBLY

Hardware List

A 1PC	B 1PC	C 1PC	D 1PC
E 1PC	F 1PC	G 1PC	H 1PC
I 1PC	J 1PC	K 1PC	L 2PCS
M 1PC	N 1PC	O 1PC	P 1PC
Q 2PCS	R 2PCS	S 1PC	T 2PCS
U 1PC	V 2PCS	① 37PCS Ø15X11mm	② 37PCS Ø6.5X35mm
③ 39PCS Ø8X30mm	④ 12PCS Ø5X16mm	⑤ 11PCS Ø4.2X45mm	⑥ 4PCS Ø35mm



PRODUCT ASSEMBLY

			
Ø4X14mm		M4X19mm	Ø3X12mm
⑦ 24PCS	⑧ 2PCS	⑨ 2PCS	⑩ 36PCS
			
⑪ 1PC			

PRODUCT ASSEMBLY

 Check the package contents before getting started !

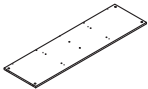
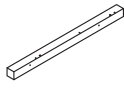
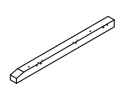
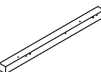
STEP 1

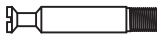
			
A 1PC	B 1PC	H 1PC	I 1PC
			
J 1PC	K 1PC	Q 2PCS	② 37PCS

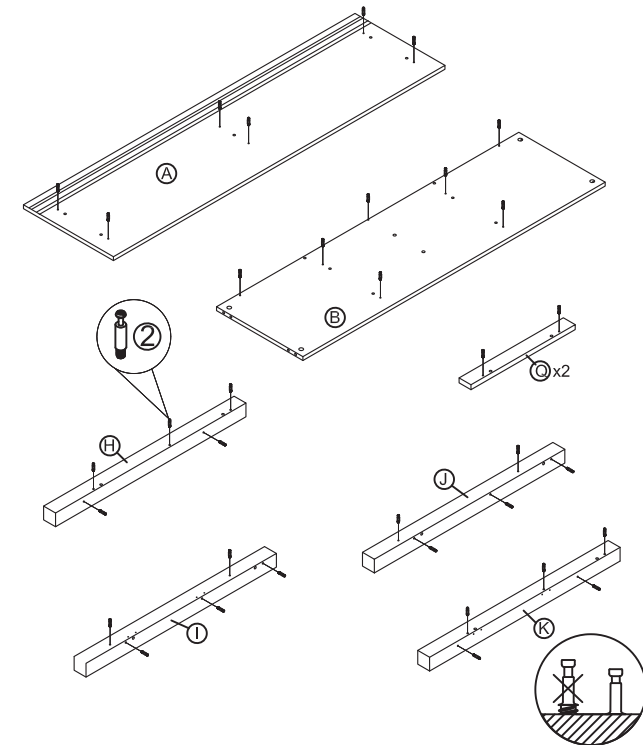

PRODUCT ASSEMBLY

STEP 2

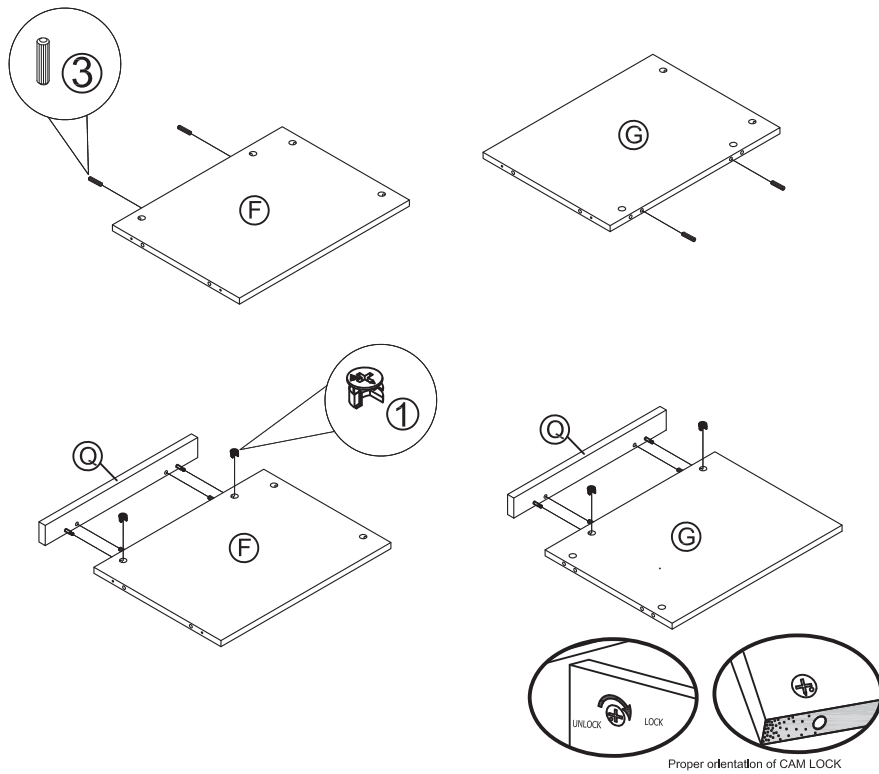
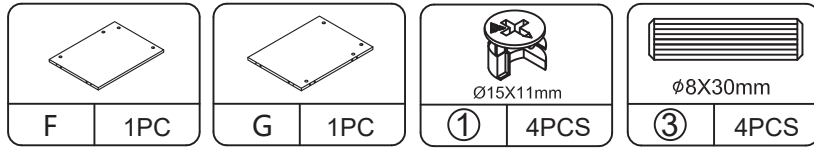

PRODUCT ASSEMBLY

STEP 3

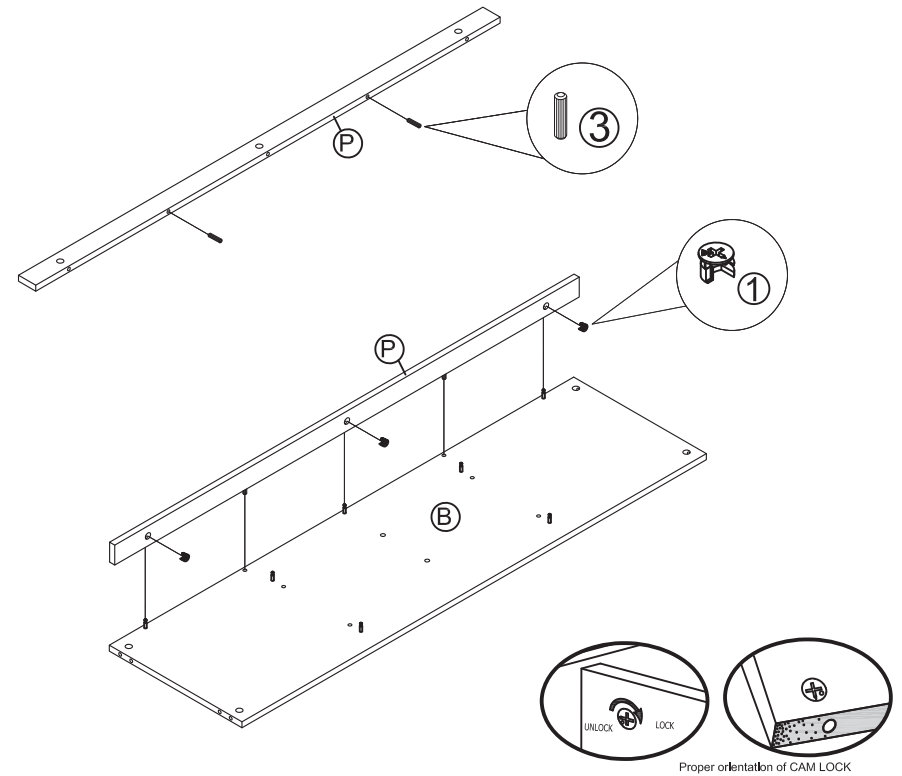
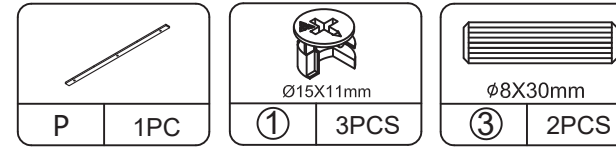

PRODUCT ASSEMBLY

STEP 4

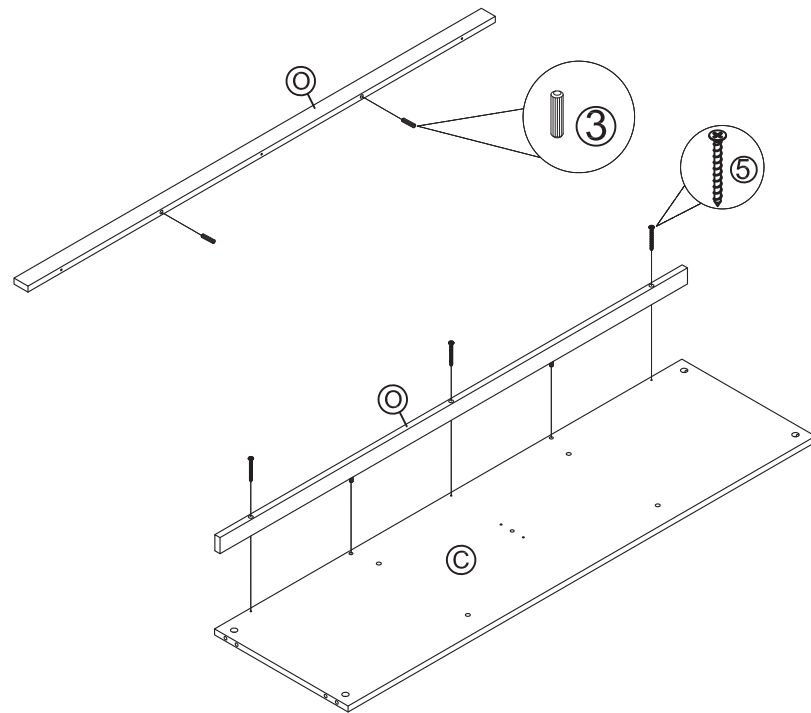
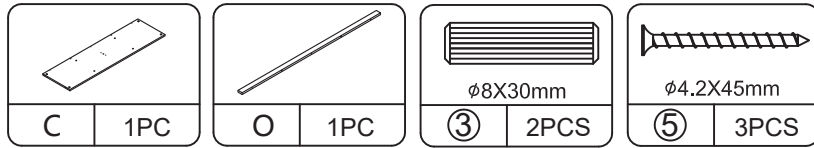

PRODUCT ASSEMBLY

STEP 5

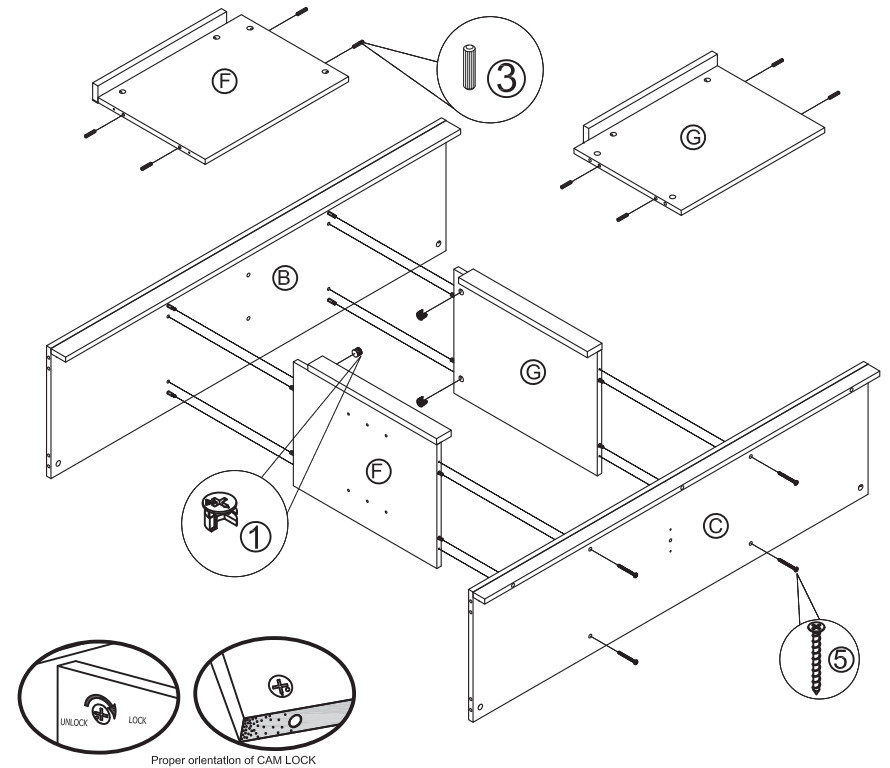
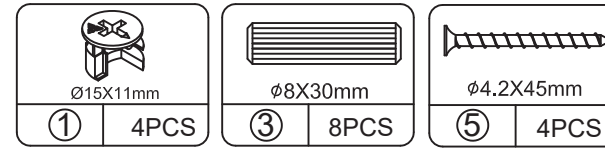

PRODUCT ASSEMBLY

STEP 6

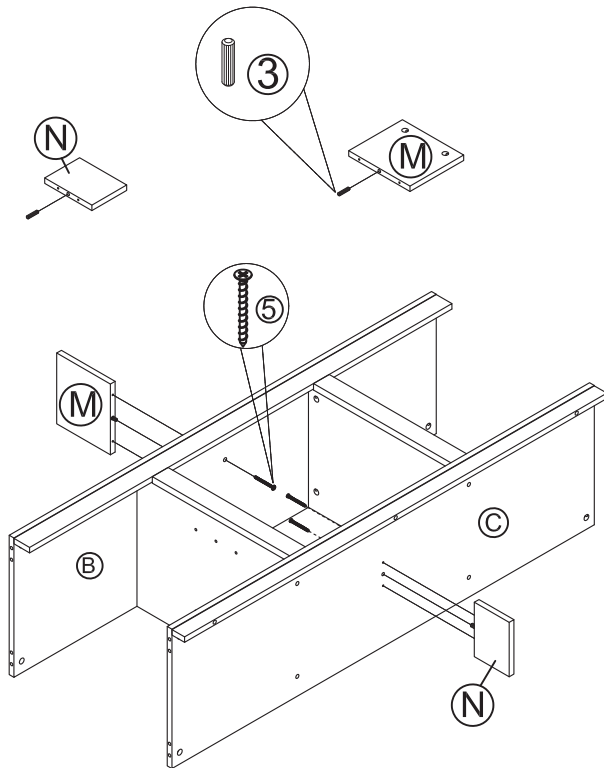
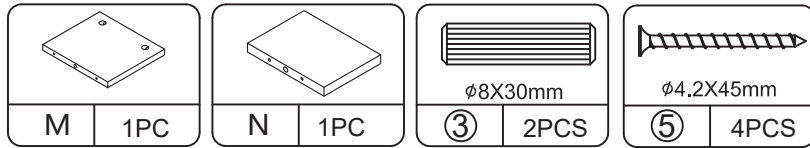

PRODUCT ASSEMBLY

STEP 7

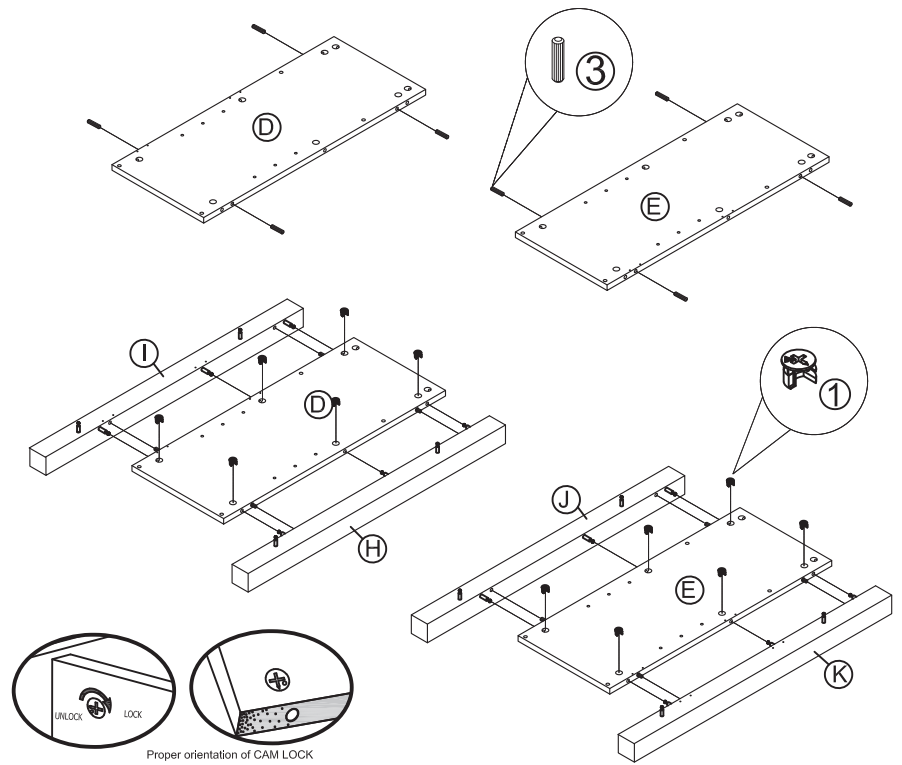
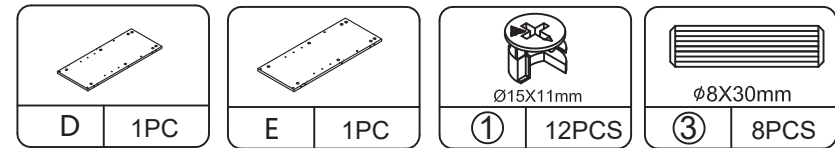

PRODUCT ASSEMBLY

STEP 8

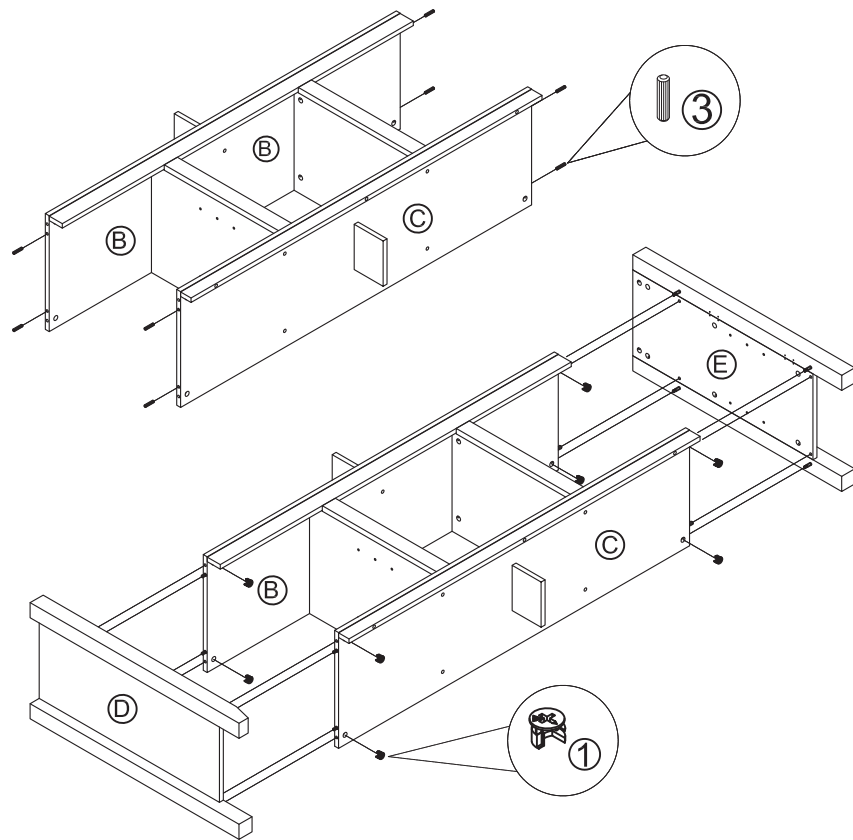
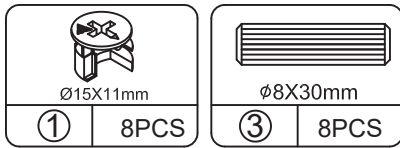

PRODUCT ASSEMBLY

STEP 9

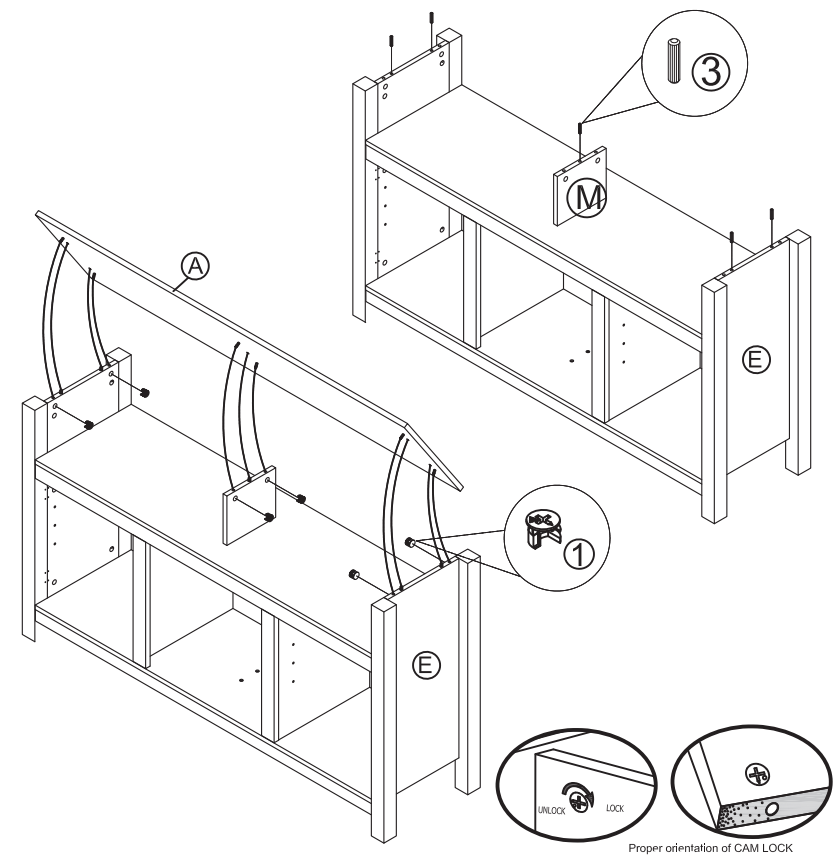
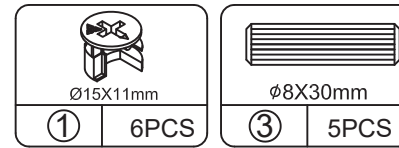

PRODUCT ASSEMBLY

STEP 10

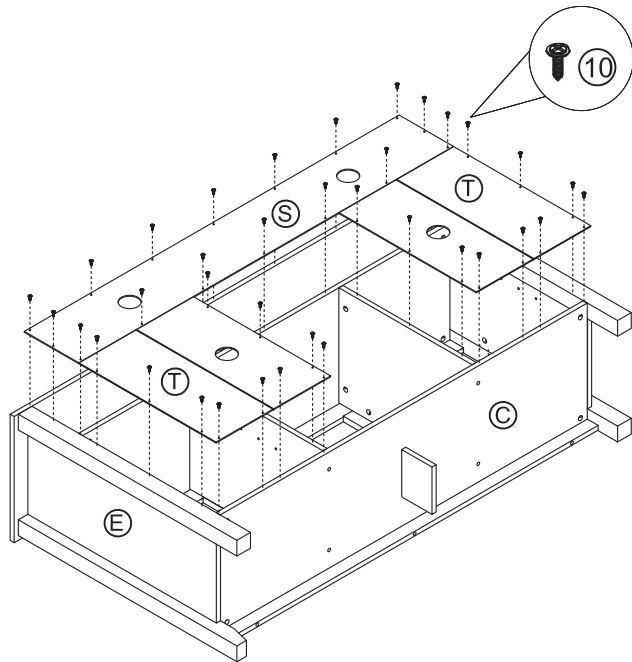
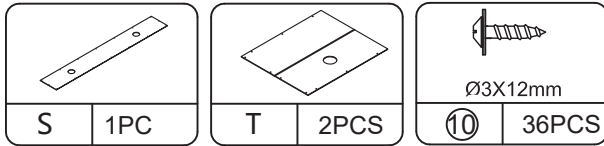

PRODUCT ASSEMBLY

STEP 11

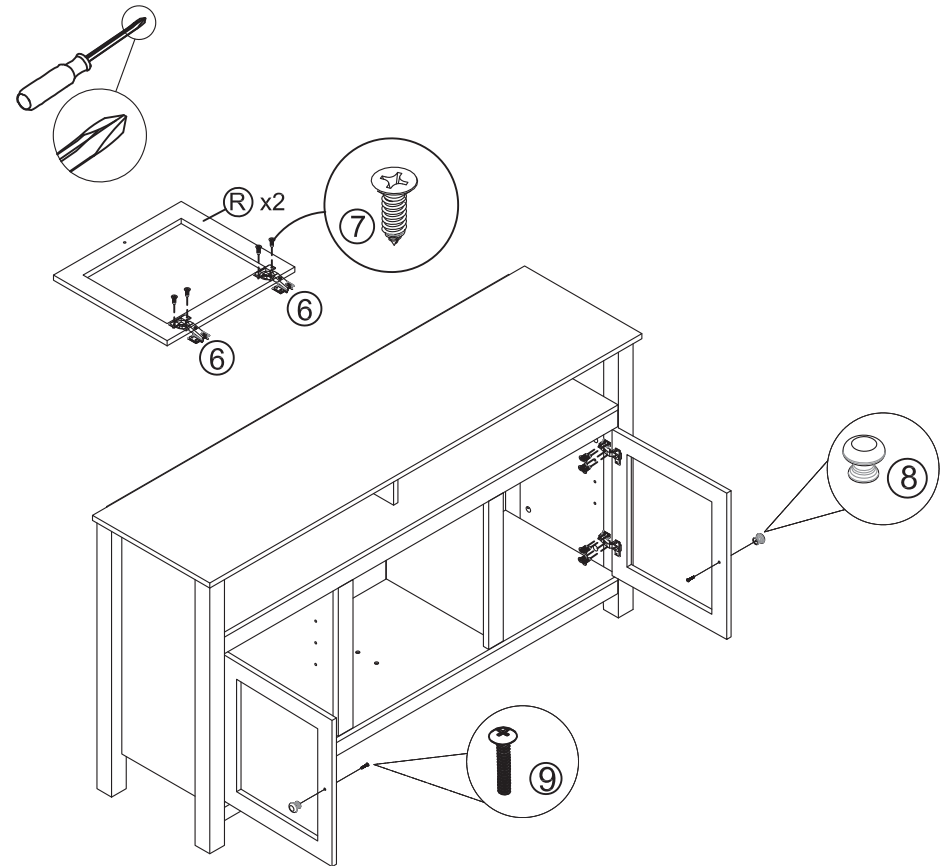
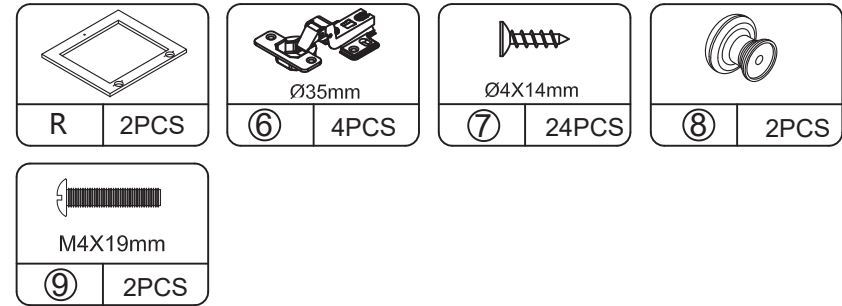

PRODUCT ASSEMBLY

STEP 12

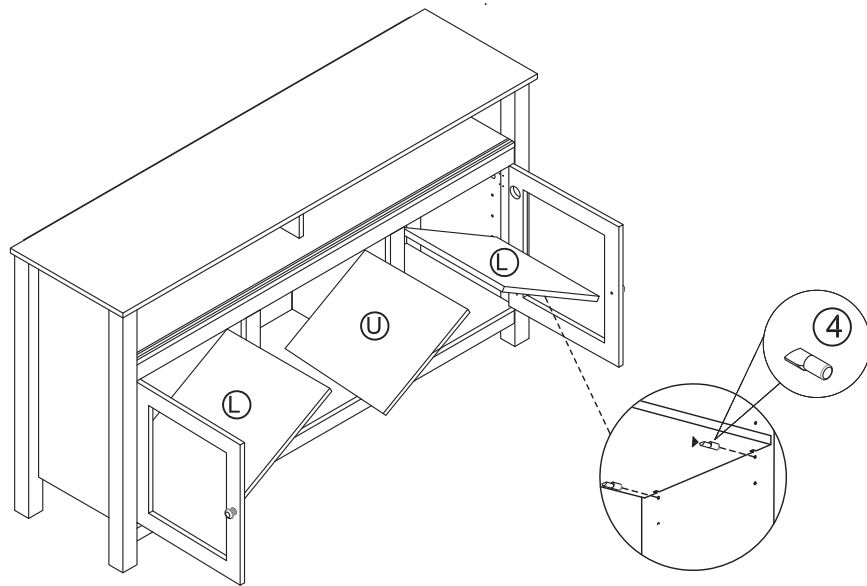
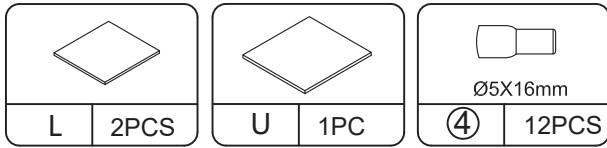

PRODUCT ASSEMBLY

STEP 13

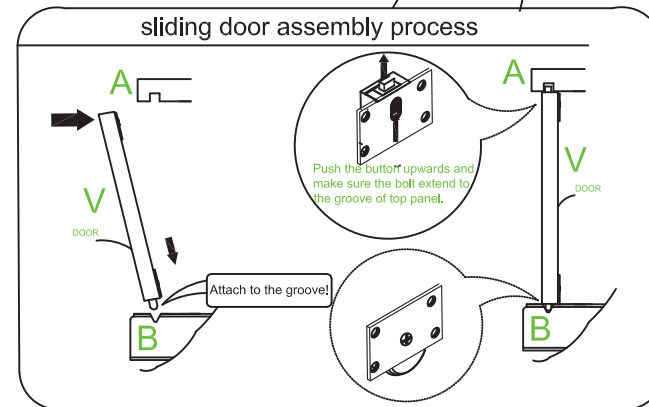
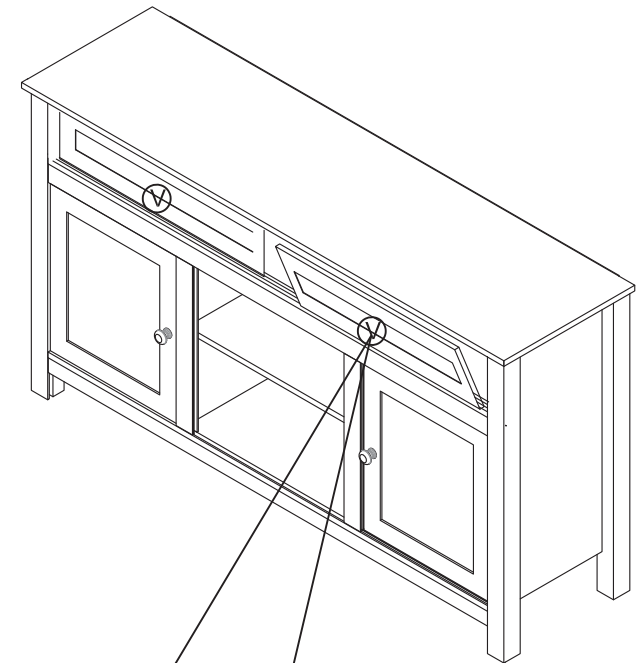
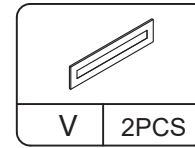

PRODUCT ASSEMBLY

STEP 14

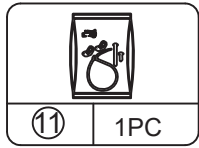

PART LIST	FIGURE	QUANTITY	DESCRIPTION
11.1		2PC	LONG SCREW (Dia.4mmX38mmL)
11.2		2PC	SHORT SCREW (Dia.4mmX19mmL)
11.3		4PC	METAL "L"BRACKET
11.4		2PC	PLASTIC ANCHOR
11.5		2PC	CABLE

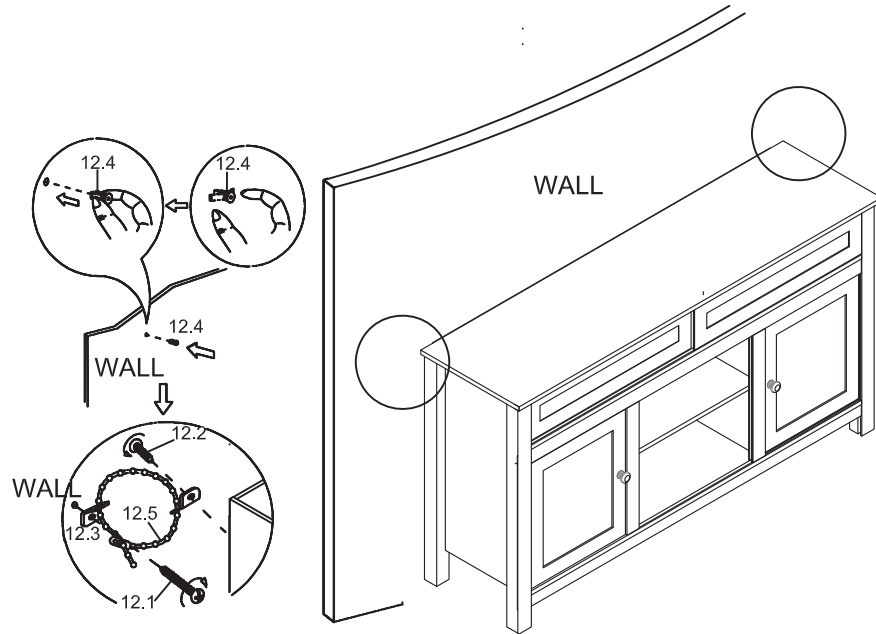
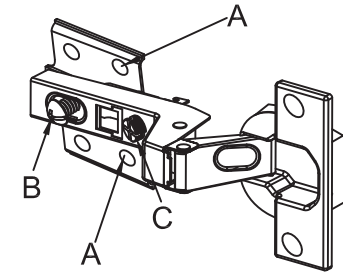

To adjust the vertical height.

Loosen the four screws "A" on both hinges. Two of them are usually in slotted holes which allows you to adjust up or down by a few mm. Then tighten back up.

To adjust depth.

Loosen screw "B" and adjust door, if the door can not be adjusted, please loosen screw "C", then try again. Tighten screw "B" and "C".

To adjust side ways.

Turning the screw "C" on BOTH hinges on each door.

Follow the instructions printed on the plastic bag containing the tipping restraint hardware to attach the tip-over restraints to the unit and the wall.

NOTE: The tipping restraint hardware included is for drywall construction. It will be necessary to drill holes for the wall anchors. Depending upon your wall construction, different anchor hardware may be required. Please contact your local hardware store for assistance.