

User Manual

JAXPETY

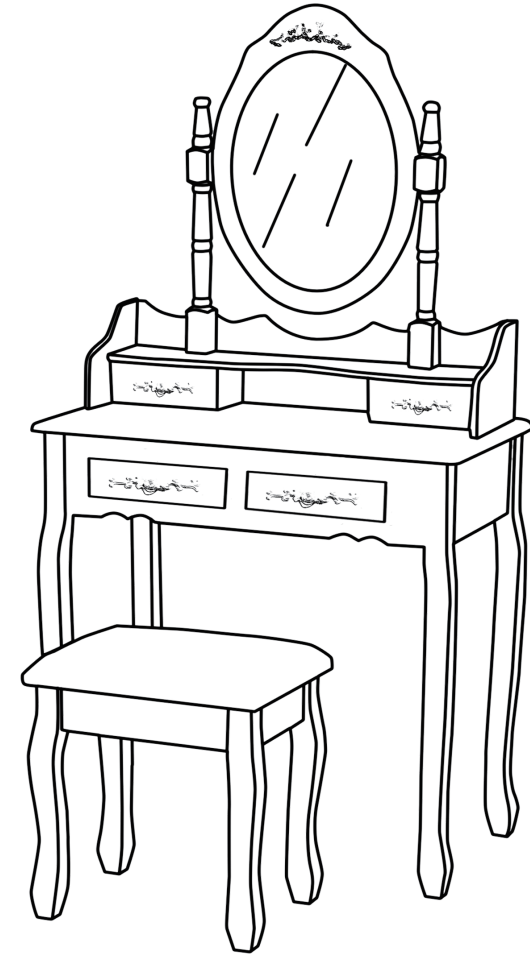

Scan ! To find more surprise!

You need

1 Tools required

A Phillips head screwdriver is required for the assembly of this product. (not included)

Power tools should not be used to assemble this product.

2 1 persons is needed

3 Take 30 minutes

Technical Specifications	
Brand	JAXPETY
Size	750X400X1430mm
Max weight capacity	330LBS

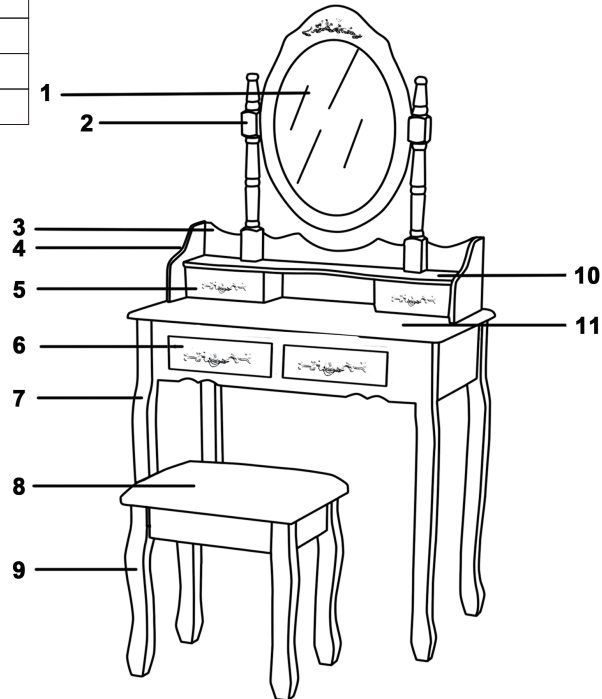

NO NON	DESCRIPTION LA DESCRIPTION	QUANTITY QUANTITE	NO NON	DESCRIPTION LA DESCRIPTION	QUANTITY QUANTITE
1	MIRROR	1	7	TABLE LEGS	4
2	MIRROR FIXTURE	2	8	CUSHION	1
3	BOARD	1	9	STOOL LEGS	4
4	BOARD	2	10	BOARD	1
5	SMALL DRAWER	2	11	TABLE BODY	1
6	MAIN DRAWER	2			

Hardware List

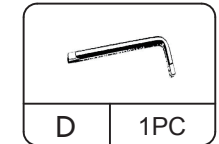
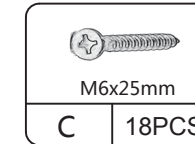
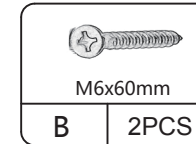

PRODUCT ASSEMBLY

⚠ Check the package contents before getting started !

STEP 1

USE SCREWS(A) TO ATTACH THE TABLE BODY(11) TO THE TABLE LEGS(7).

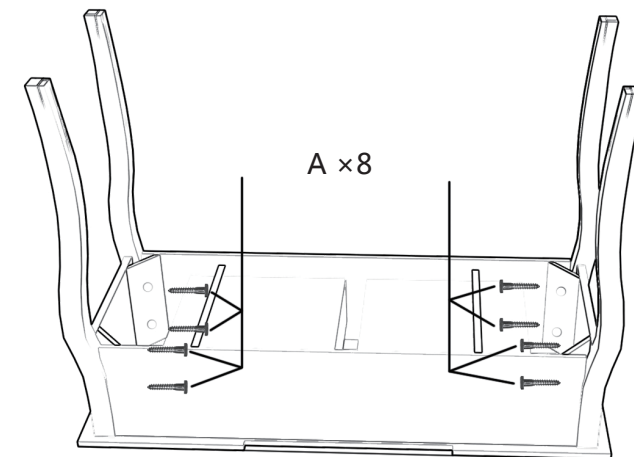

Do not screw all the screws when installing the table legs and stool legs. Keep half-screw state until all installation adjustments are complete before screwing the screws.

STEP 2

USE SCREWS(C) TO CONNECT BOARD(3) BOARD(4) AND BOARD(10) TOGETHER.

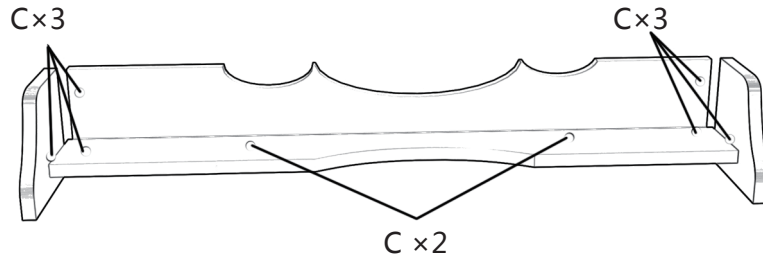

STEP 3

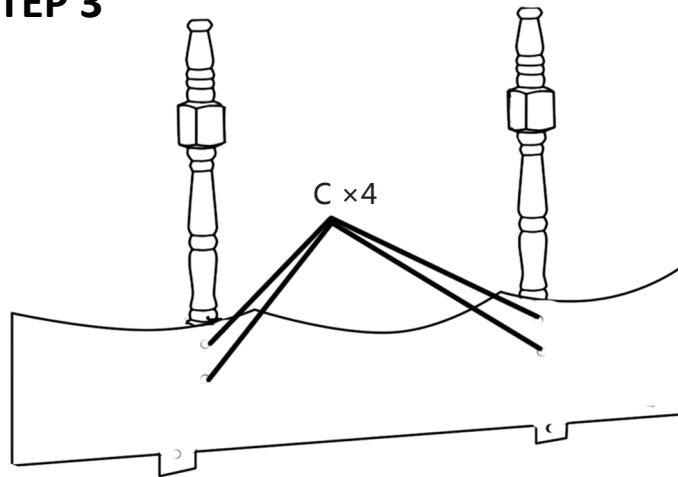

USE SCREWS (C) TO CONNECT STEP2 WITH THE COMPLETED PART OF THE SECOND STEP.

STEP 4

USE SCREWS C TO CONNECT THE TABLE BODY(11) AND THE THIRD STEP OF THE ASSEMBLED PARTS.

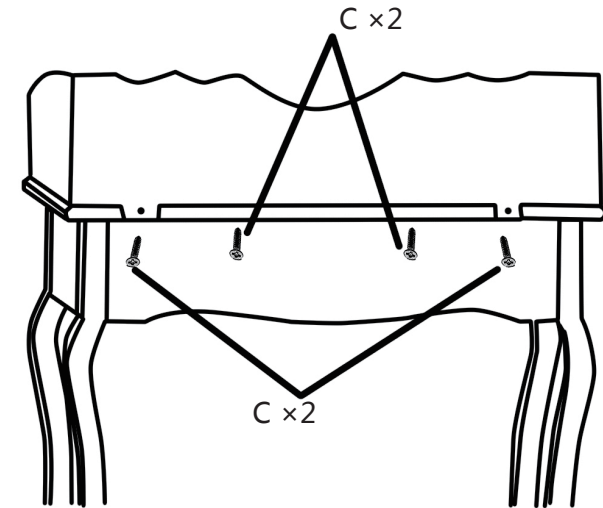

STEP 5

USE SCREWS B TO CONNECT MIRROR FIXTURE(2) TO MIRROR(1).

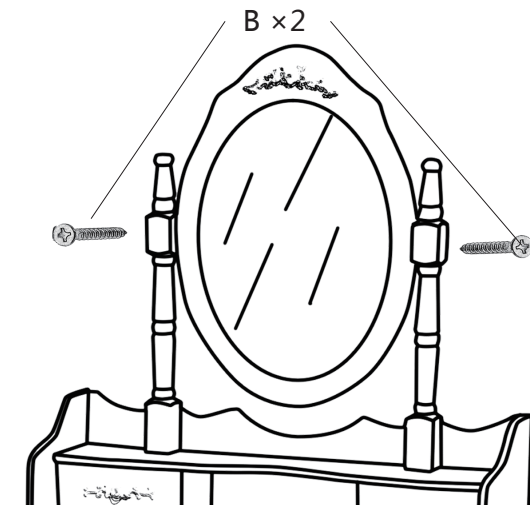

STEP 6

PLEASE THE SMALL DRAWER IN THE POSITION SHOWN AND ATTACH IT TO THE ASSEMBLED PART IN STEP 5 WITH THE SCREW(C).

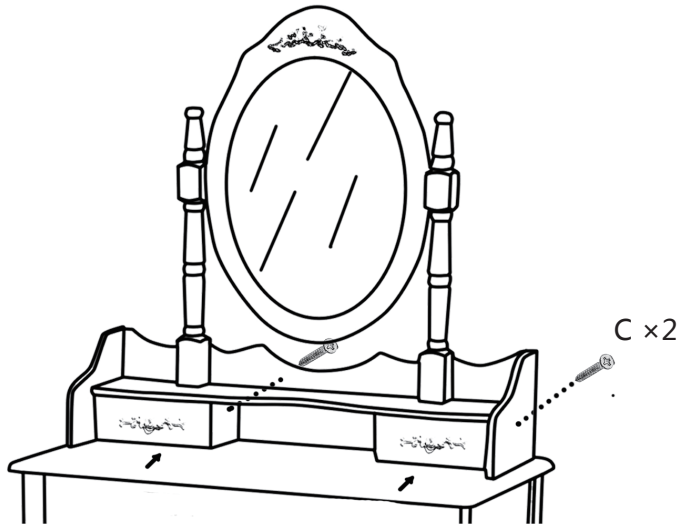

STEP 7

USE SCREWS(A) TO CONNECT STOOL LEGS AND STOOL.

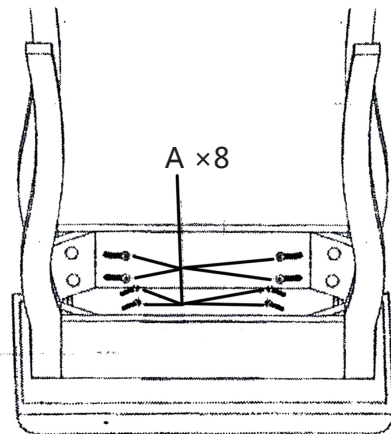

Do not screw all the screws when installing the table legs and stool legs. Keep half-screw state until all installation adjustments are complete before screwing the screws.

STEP 8

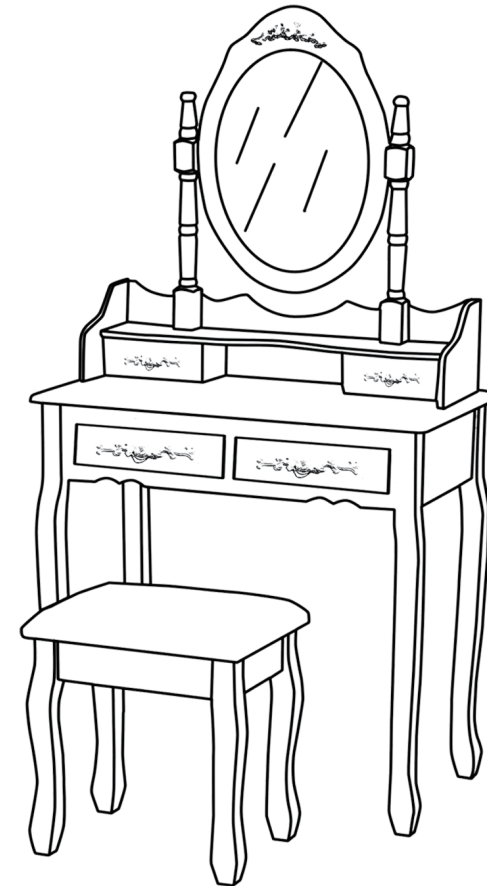

**FINISH
TERMINER**