

# User Manual

# JAXPETY

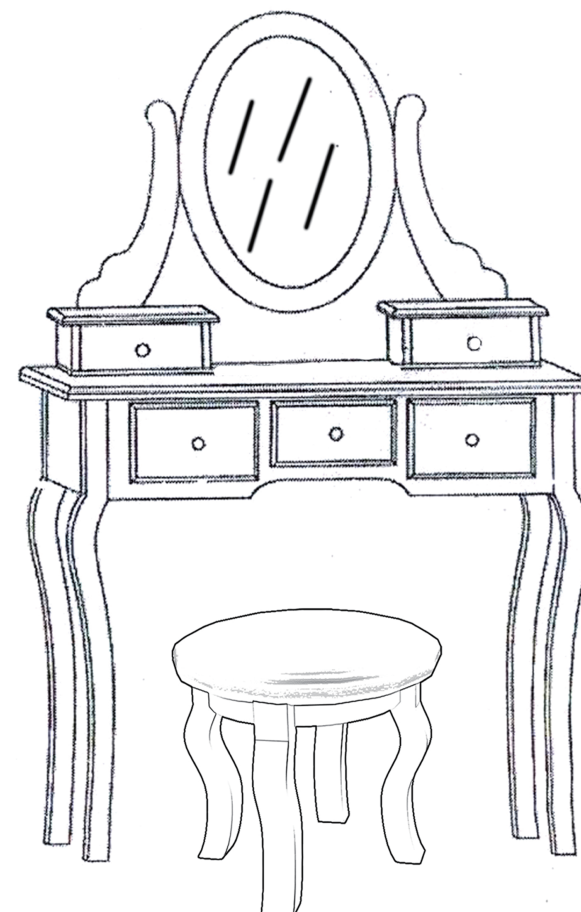

Scan ! To find more surprise!

**JAXPETY** | 

## You need

**1 Tools required**

A Phillips head screwdriver is required for the assembly of this product. (not included)

Power tools should not be used to assemble this product.

**2 1 person is needed**

**3 Take 30 minutes**

Technical Specifications	
Brand	JAXPETY
Size	750X400X1340mm
Max weight capacity	330LBS

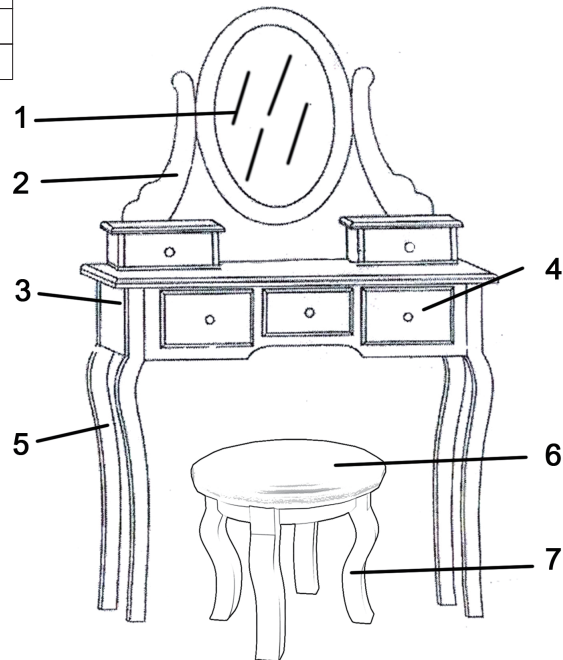

No	Description	Quantity	No	Description	Quantity
1	MIRROR	1	5	TABLE LEGS	4
2	WOODEN PROP	2	6	CUSHION	1
3	DESKTOP	1	7	CHAIR LEGS	4
4	WOODEN DRAWER	5	8		

## Hardware List

M8x50mm

A | 8PCS

M4x35mm

B | 4PCS

M4x30mm

C | 2PCS

M4x50mm

D | 2PCS

E | 1PC

M8x60mm

F | 8PCS

### PRODUCT ASSEMBLY

**!** Check the package contents before getting started !

### STEP 1

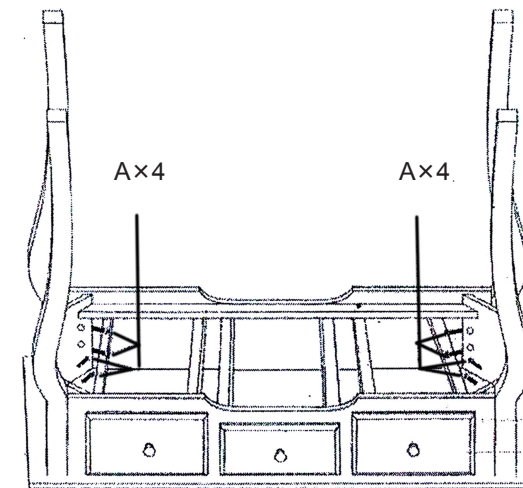

Do not screw all the screws when installing the table legs and stool legs. Keep half-screw state until all installation adjustments are complete before screwing the screws.

**STEP 2**

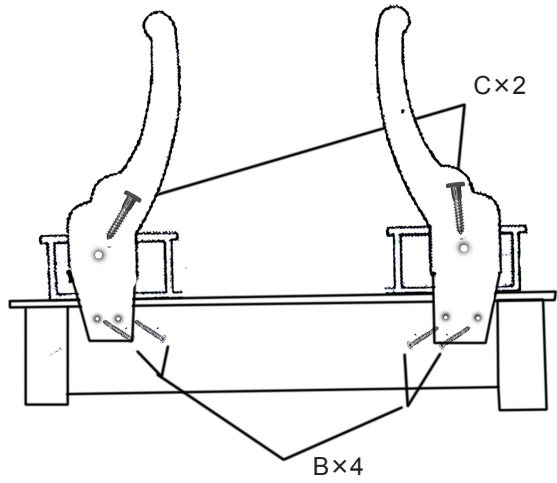

**STEP 3**

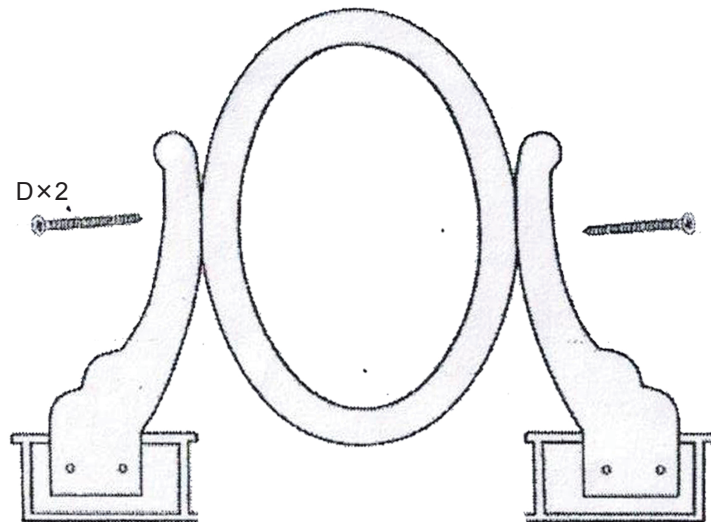

**STEP 4**

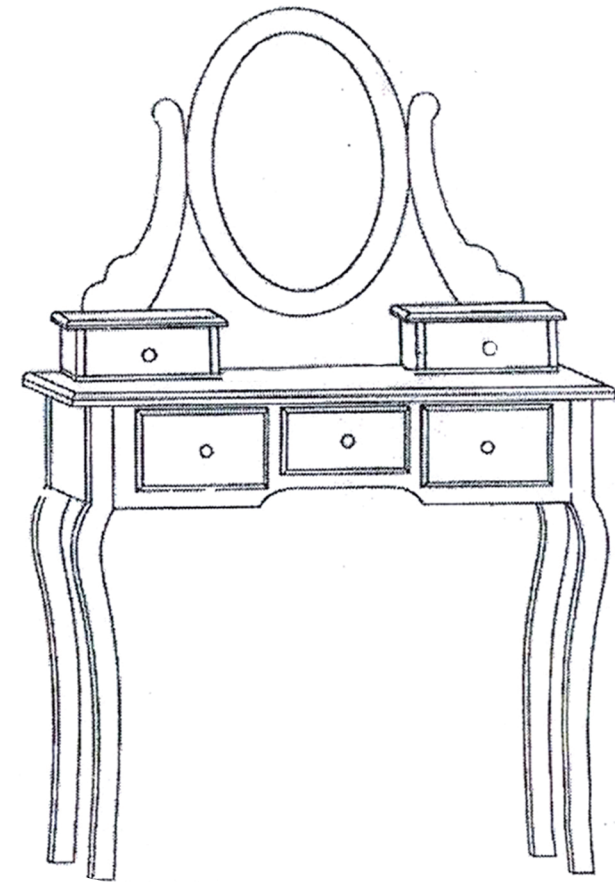

**DRESSING TABLE FINISH**

## STEP 5

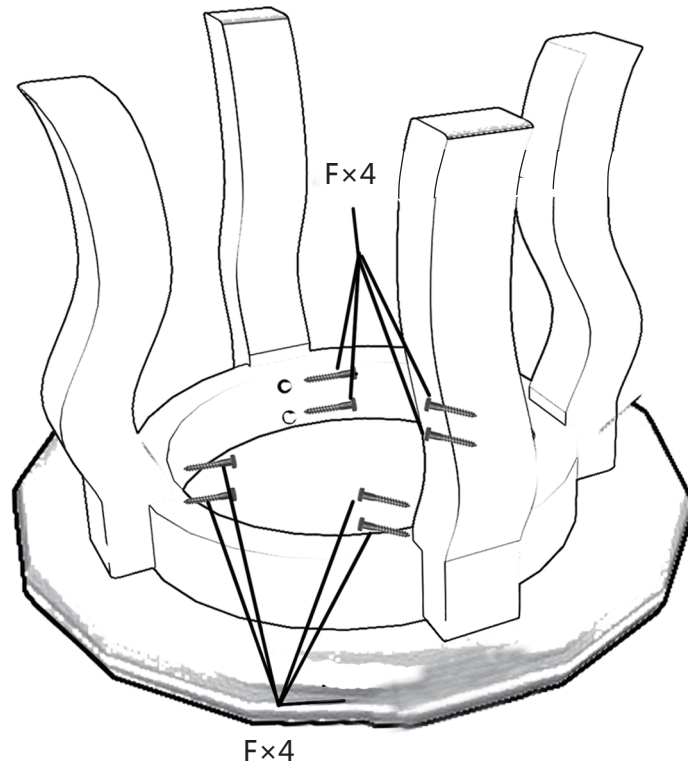

Do not screw all the screws when installing the table legs and stool legs. Keep half-screw state until all installation adjustments are complete before screwing the screws.

## STEP 6

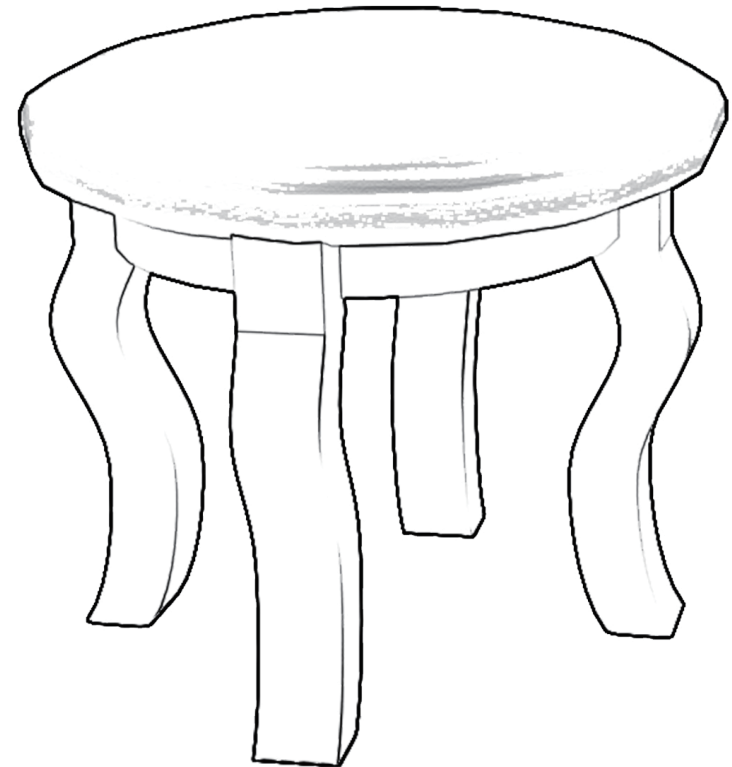

## STOOL FINISH