

User Manual

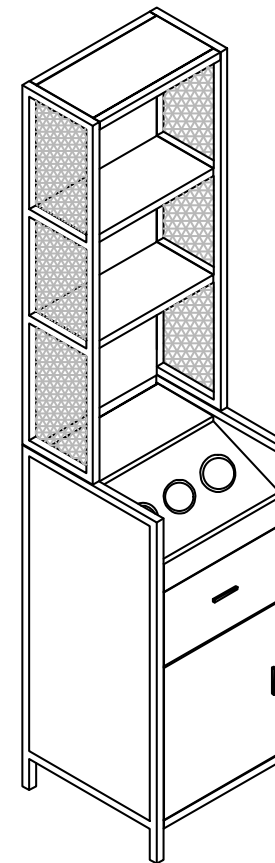

Model Number: MR11A0253

Dear Customer,

Thank you for your purchase.

RESHABLE is created to be the perfect starting spot for any barbers. Supplying top-quality barber supplies like barber chairs, salon stations, rolling makeup cases, styling drawer cabinets, hair tool holders, and more, we help people to keep their barber store running with the best equipment at the most reliable prices.

When you receive the product, please make sure that all the parts are intact. Then please browse the entire installation manual before assembly. If problems occur unsatisfactorily as follows:

- a. The outer box is damaged.**
- b. The product is damaged/bent/cracked while you open the box.**
- c. The parts/accessories/assembly tools are missing.**
- d. The product is hard to assemble.**
- e. The instructions are not clear and can not be referred to.**
- f. The product has functional problems.**
- g. Other aspects that you are not satisfied with.**

Please do not hesitate to contact us for help (Be sure to mark the SKU NUMBER, e.g., MR11R0246, and the TRACKING NUMBER). Our RESHABLE team with factory direct after-sales service will reply within 24 hours and do our best to resolve the problem for you. Our service is available at any time.

RESHABLE
for Profession and Creativity!

Sincerely,
RESHABLE Team

You need

1 Tools required



A Phillips head screwdriver is required for the assembly of this product. (not included)

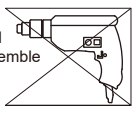





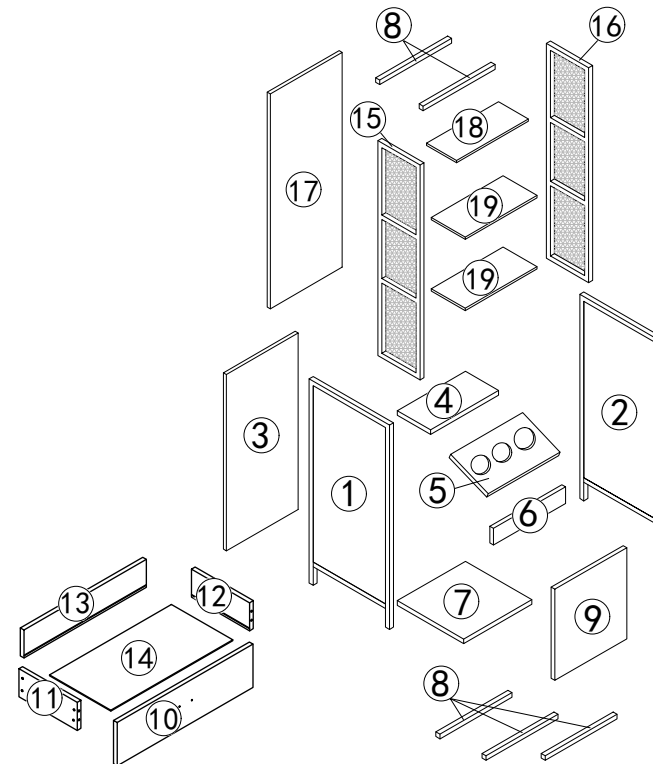



























Power tools should not be used to assemble this product.

2 2 persons needed

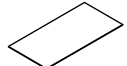
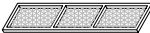
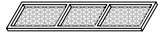
Hardware List

 M6x36mm A 12PCS	 M15x12mm B 12PCS	 M4x16mm C 20PCS	 M6x35mm D 10PCS
 M7x40mm E 28PCS	 80mm F 2PCS	 M4x18mm G 4PCS	 M4x35mm H 4PCS
 M7x60mm J 4PCS	 K 1PC	 L 2PCS	 M 2PCS
 N 4PCS	 P 2PCS	 Q 1PC	 ① 1PC
 ② 1PC	 ③ 1PC	 ④ 1PC	 ⑤ 1PC
 ⑥ 1PC	 ⑦ 1PC	 ⑧ 5PCS	 ⑨ 1PC
 ⑩ 1PC	 ⑪ 1PC	 ⑫ 1PC	 ⑬ 1PC
 ⑭ 1PC	 ⑮ 1PC	 ⑯ 1PC	 ⑰ 1PC

	
⑱ 1PC	⑲ 2PCS

PRODUCT ASSEMBLY

⚠ Check the package contents before getting started!

STEP 1

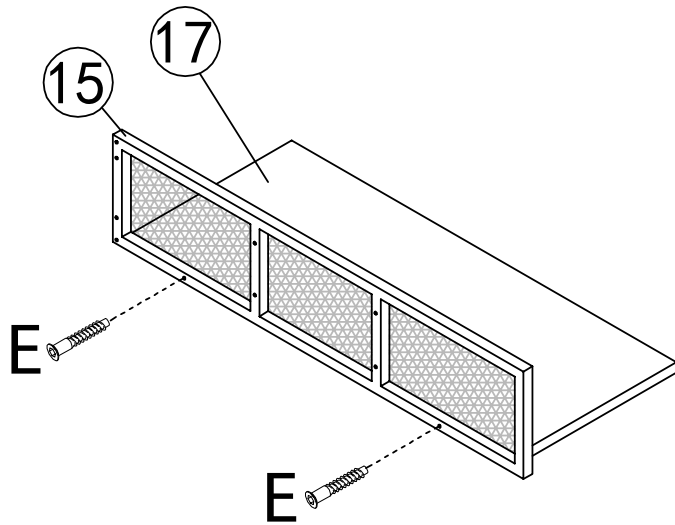
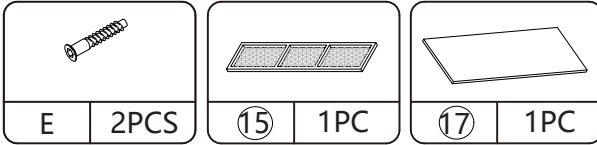

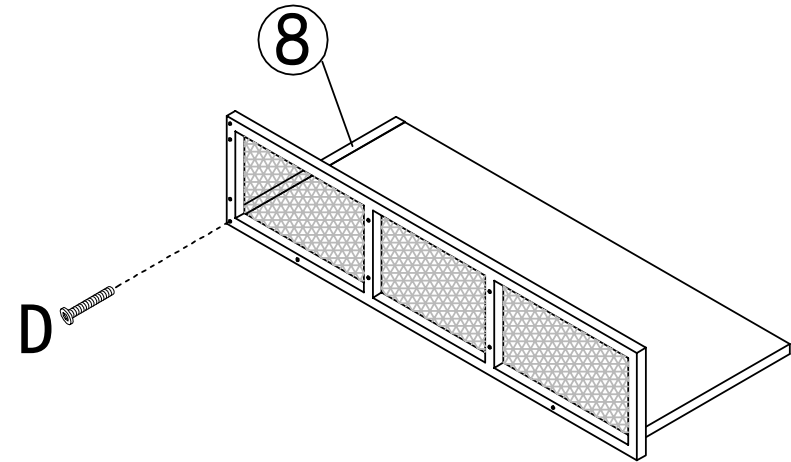
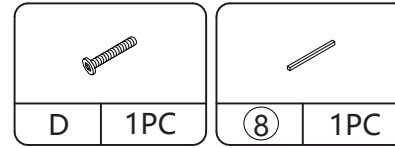

PRODUCT ASSEMBLY

STEP 2



PRODUCT ASSEMBLY

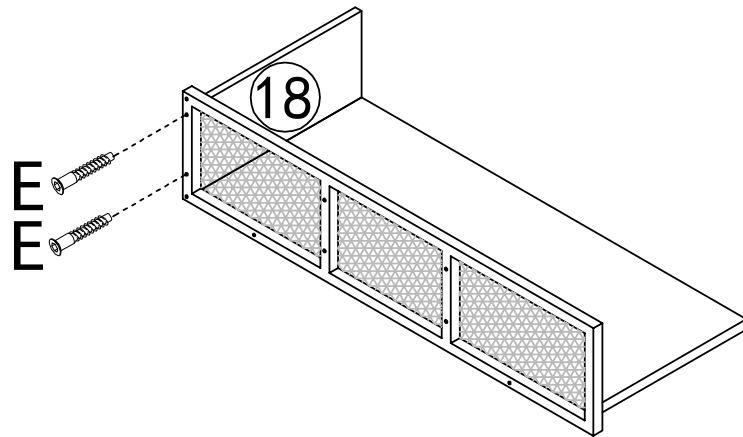

STEP 3

	
E 2PCS	18 1PC



PRODUCT ASSEMBLY

STEP 4

	
D 1PC	8 1PC

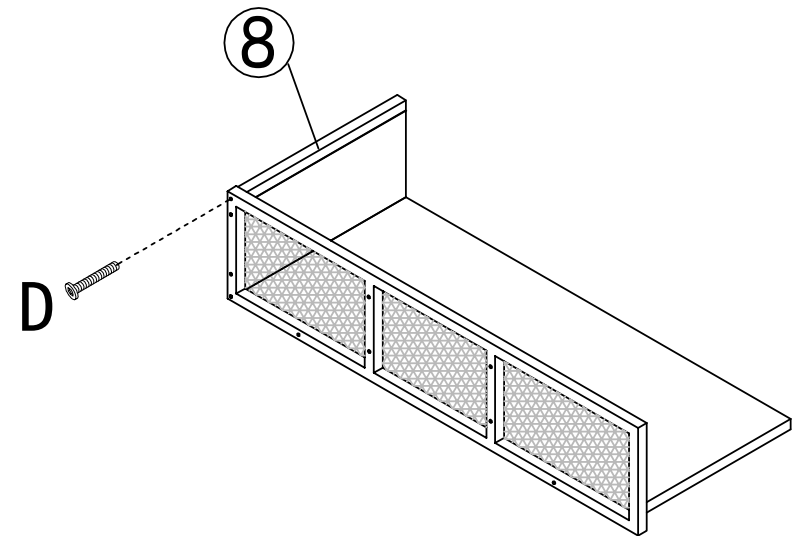

PRODUCT ASSEMBLY

STEP 5

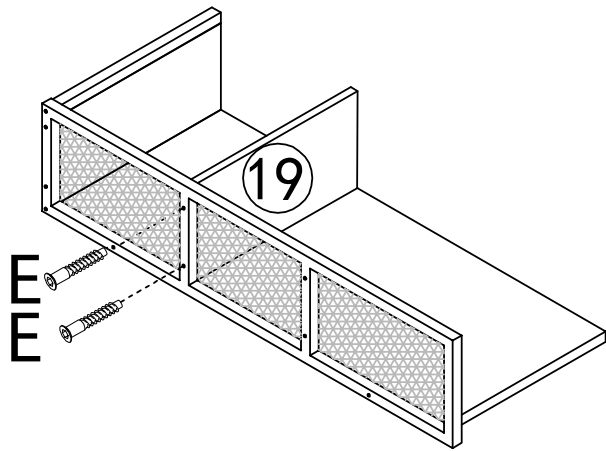
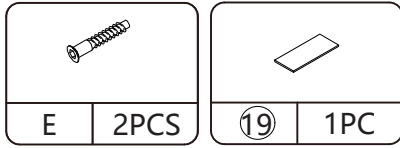

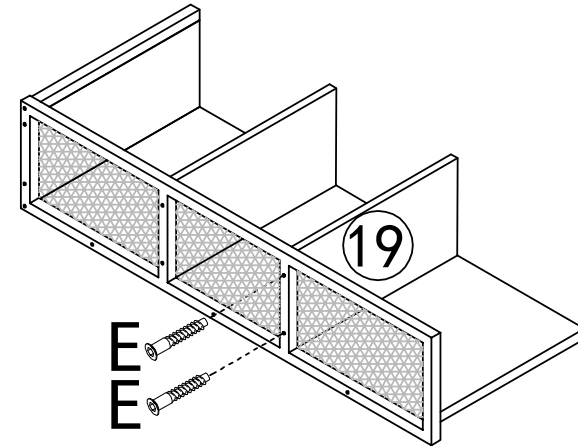
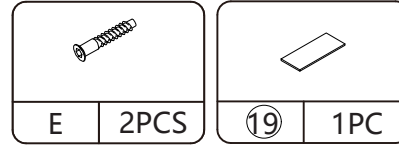

PRODUCT ASSEMBLY

STEP 6



PRODUCT ASSEMBLY

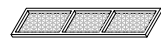

STEP 7

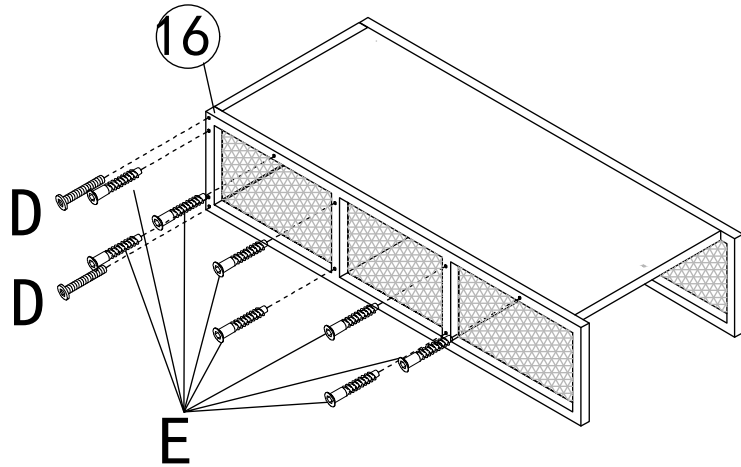
		
D 2PCS	E 8PCS	①6 1PC

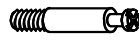

PRODUCT ASSEMBLY

STEP 8

	
A 4PCS	⑩ 1PC

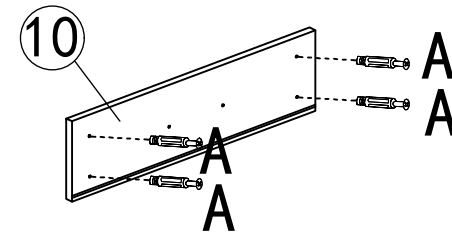

PRODUCT ASSEMBLY

STEP 9

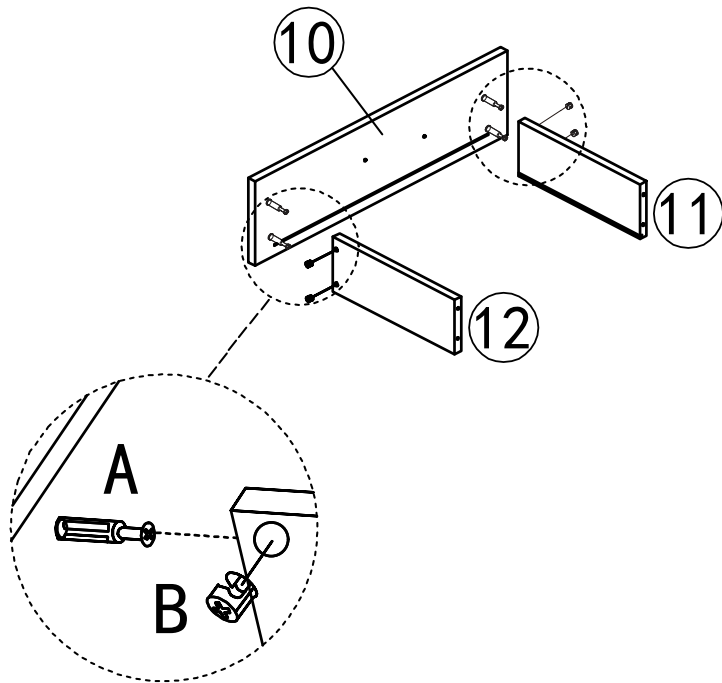
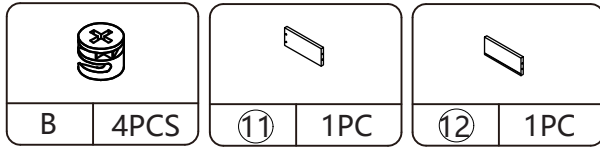

PRODUCT ASSEMBLY

STEP 10

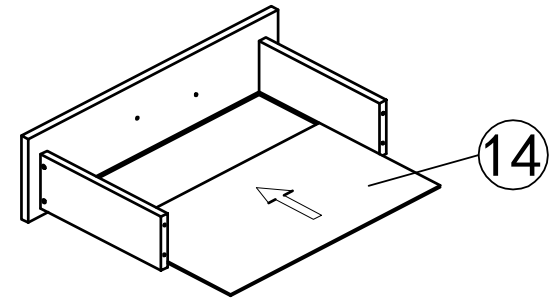
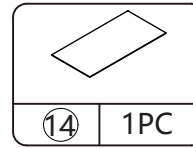

PRODUCT ASSEMBLY

STEP 11

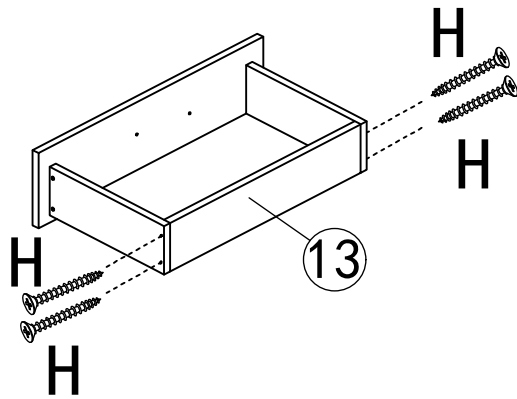
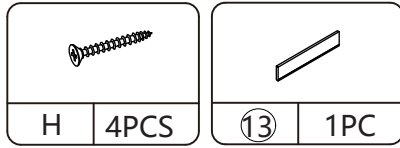

PRODUCT ASSEMBLY

STEP 12

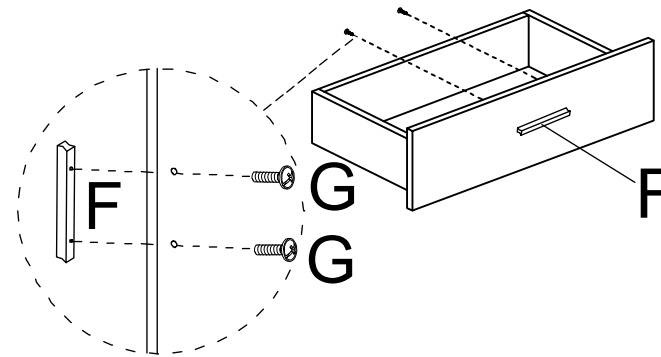
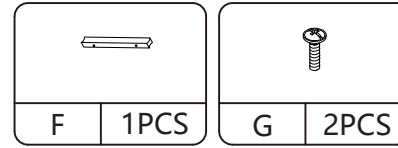

PRODUCT ASSEMBLY

STEP 13

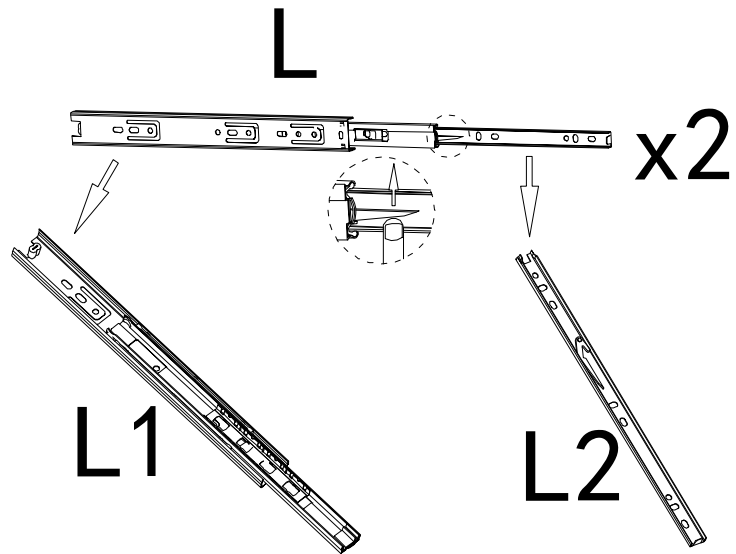
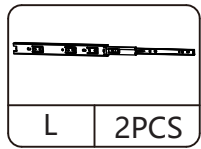

PRODUCT ASSEMBLY

STEP 14

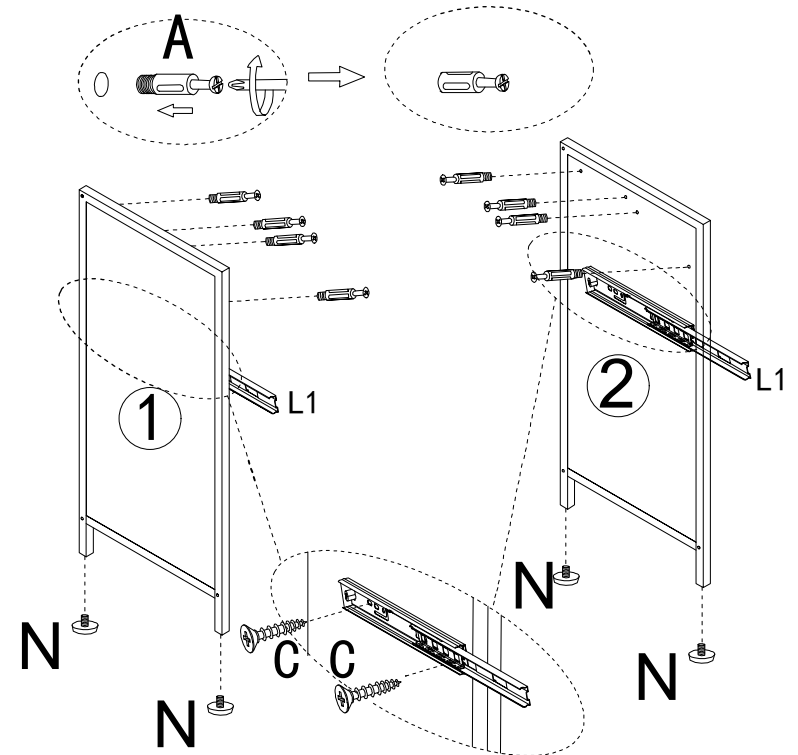
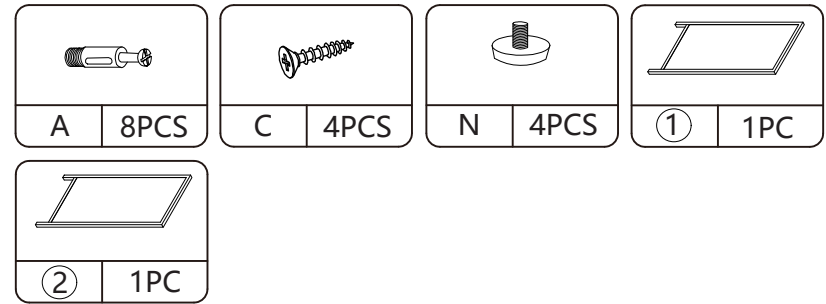

PRODUCT ASSEMBLY

STEP 15

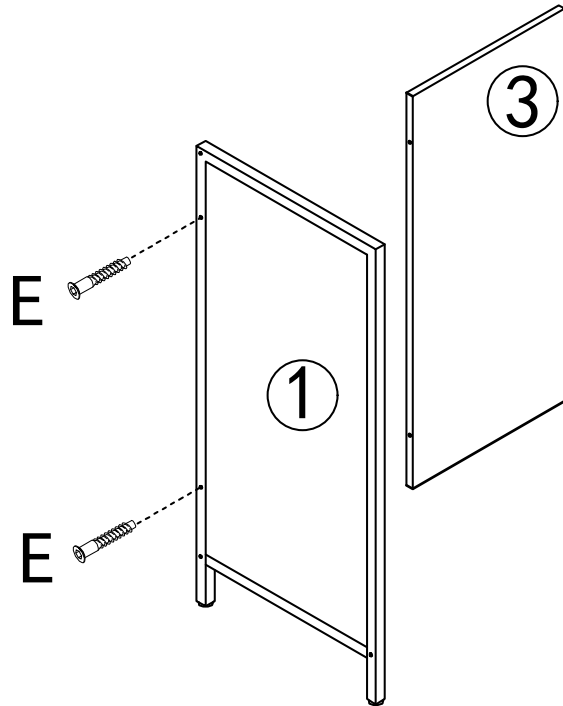
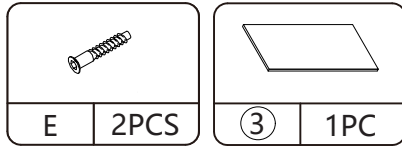

PRODUCT ASSEMBLY

STEP 16

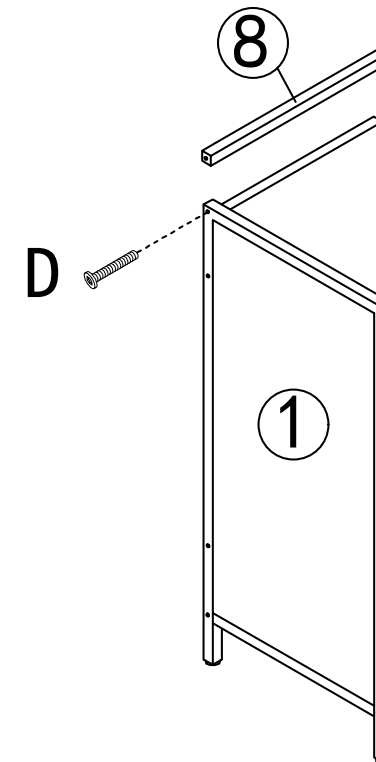
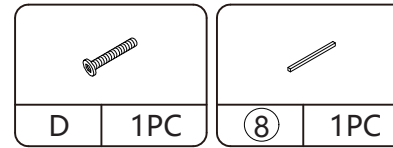

PRODUCT ASSEMBLY

STEP 17

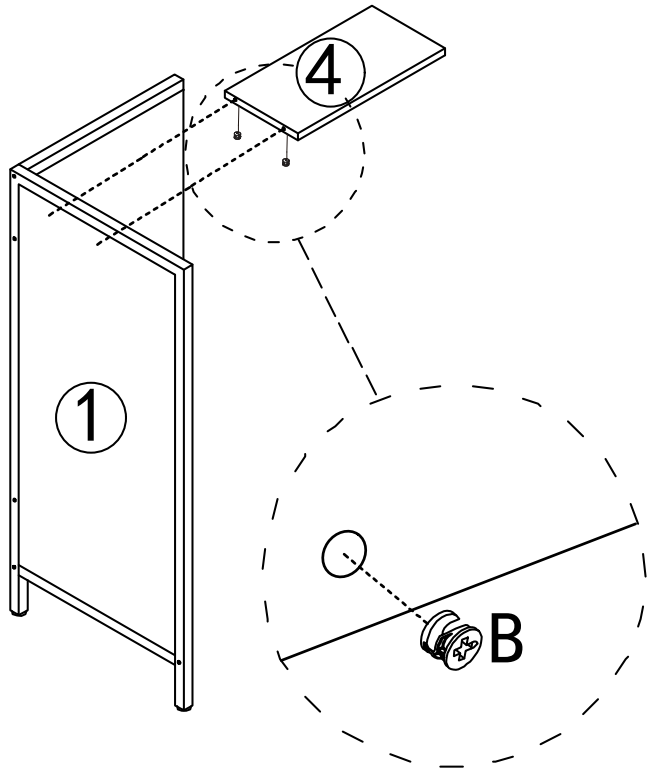
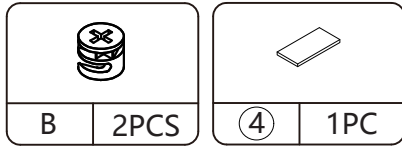

PRODUCT ASSEMBLY

STEP 18

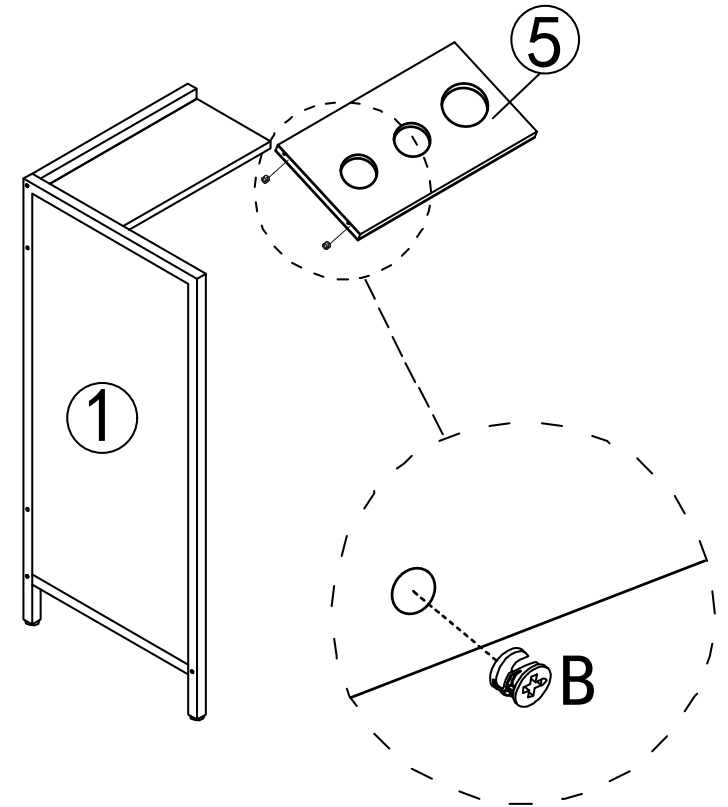
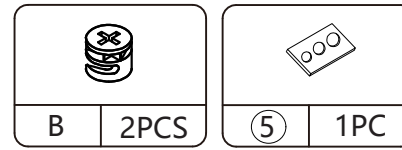

PRODUCT ASSEMBLY

STEP 19

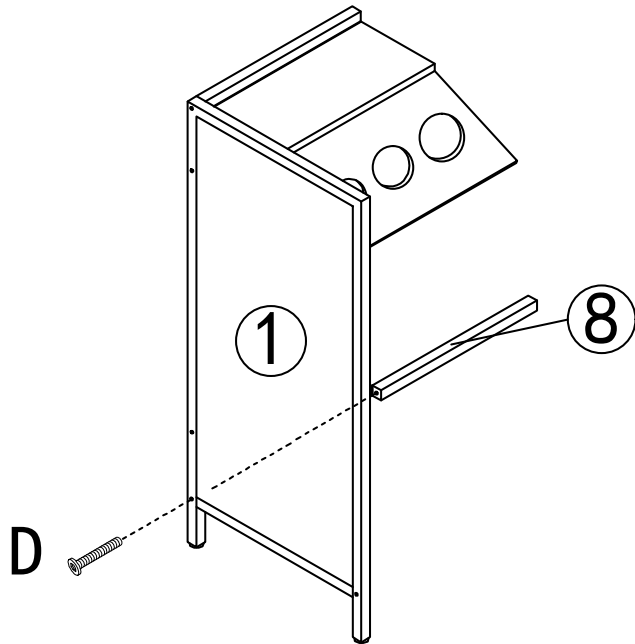

PRODUCT ASSEMBLY

STEP 20

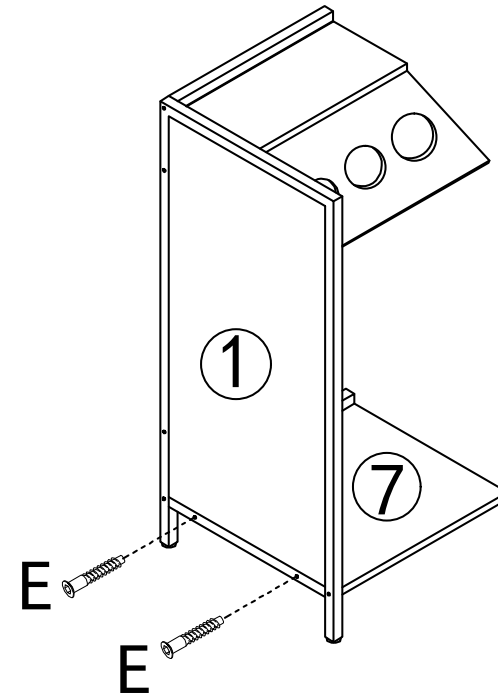
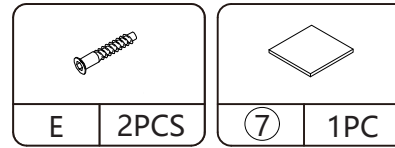

PRODUCT ASSEMBLY

STEP 21

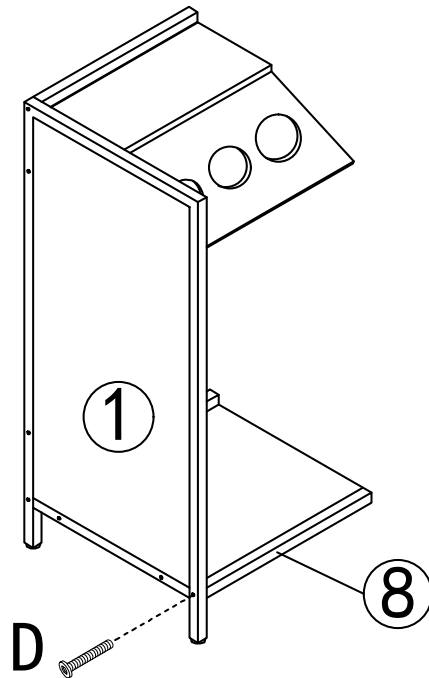

PRODUCT ASSEMBLY

STEP 22

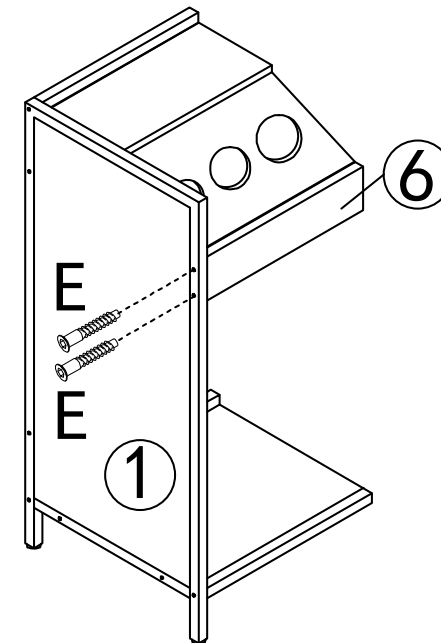
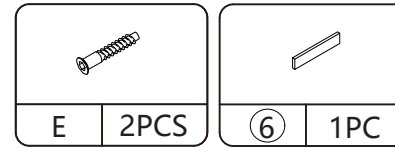

Please align the top of Panel (6) with Panel (5).

PRODUCT ASSEMBLY

STEP 23

	B	4PCS		D	3PCS		E	6PCS
--	---	------	--	---	------	--	---	------

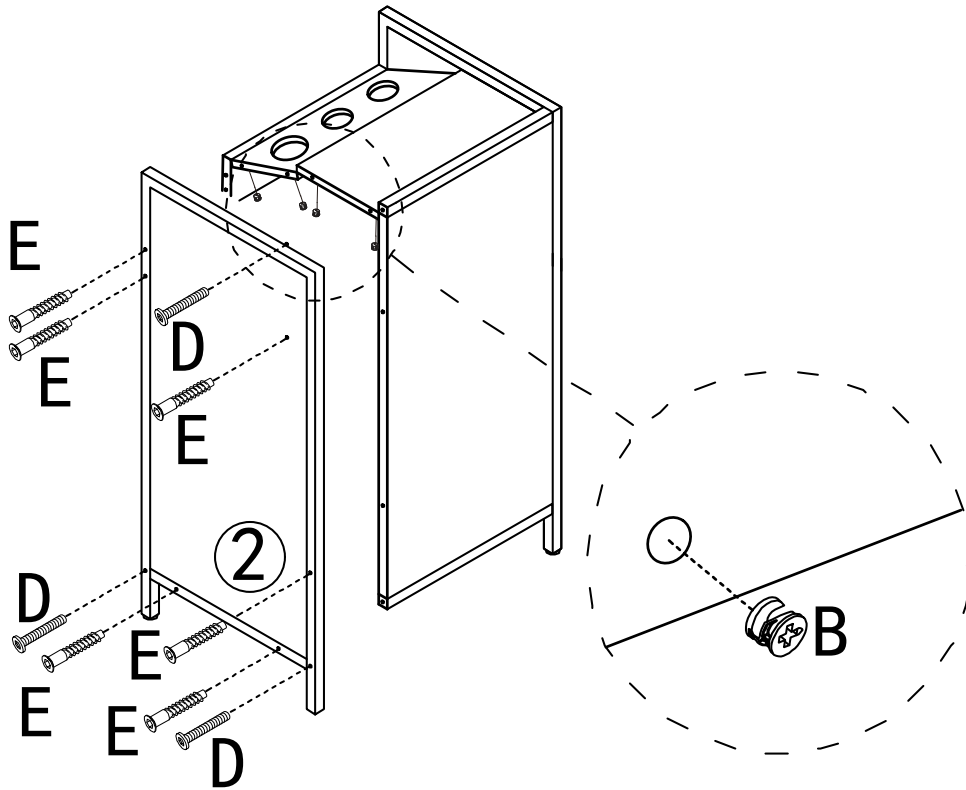

PRODUCT ASSEMBLY

STEP 24

	C	4PCS		F	1PC		G	2PCS		M	2PCS
	9	1PC									

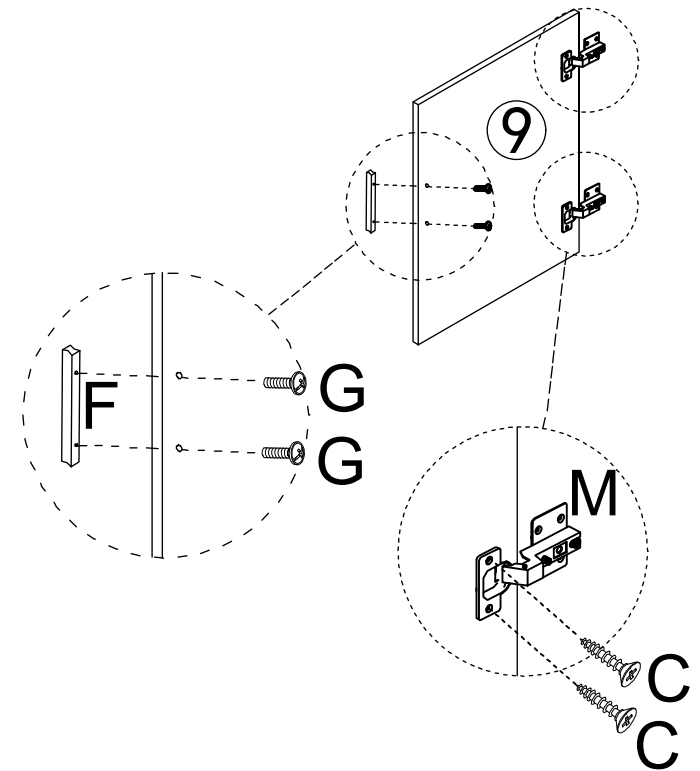

PRODUCT ASSEMBLY

STEP 25

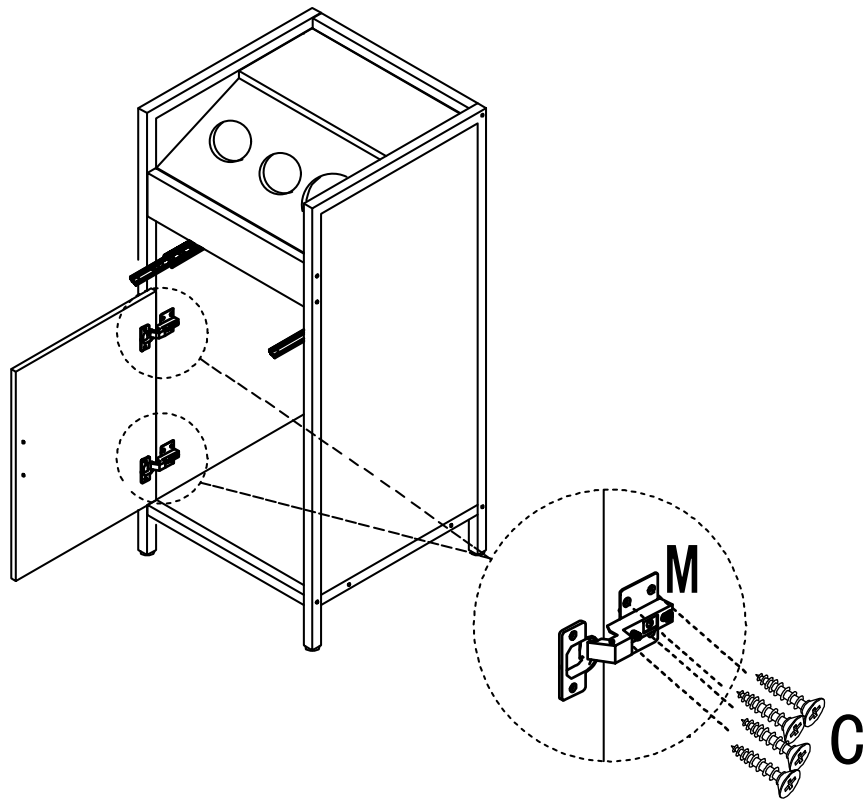
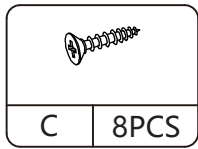

The distance between the door and the side panel can be adjusted by the hinges.

PRODUCT ASSEMBLY

STEP 26

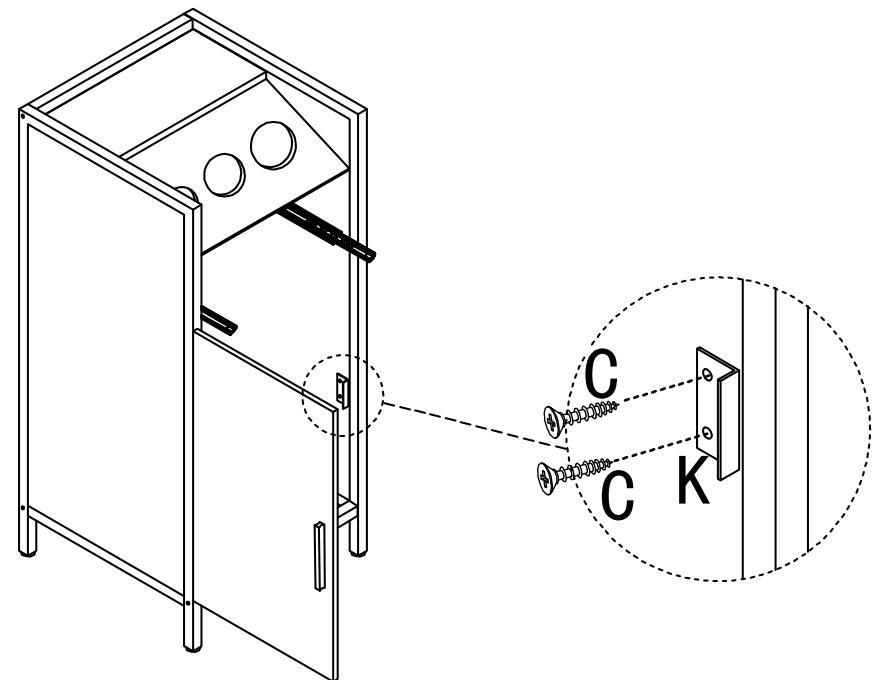
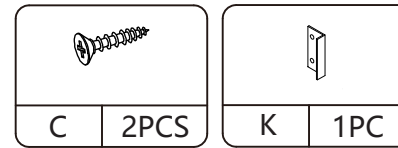

PRODUCT ASSEMBLY

STEP 27

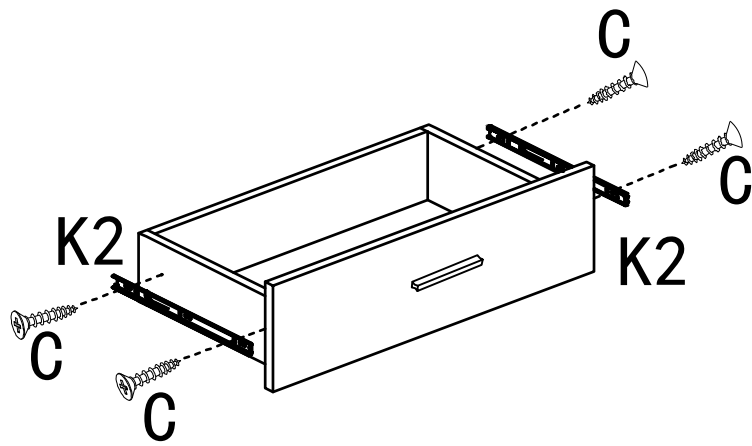
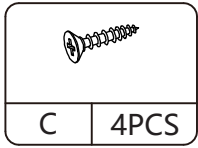

PRODUCT ASSEMBLY

STEP 28

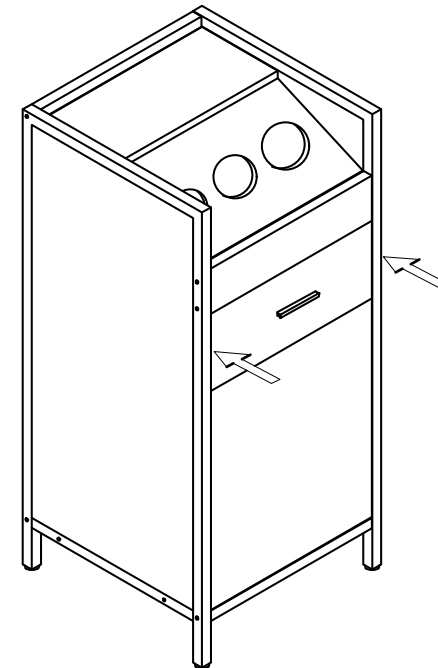

PRODUCT ASSEMBLY

STEP 29

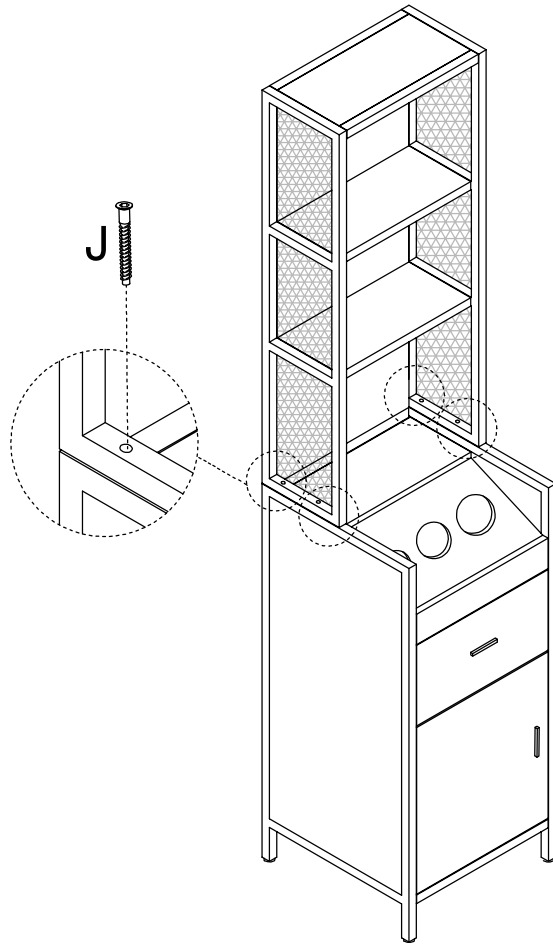
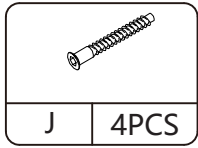

PRODUCT ASSEMBLY

STEP 30

