

# User Manual

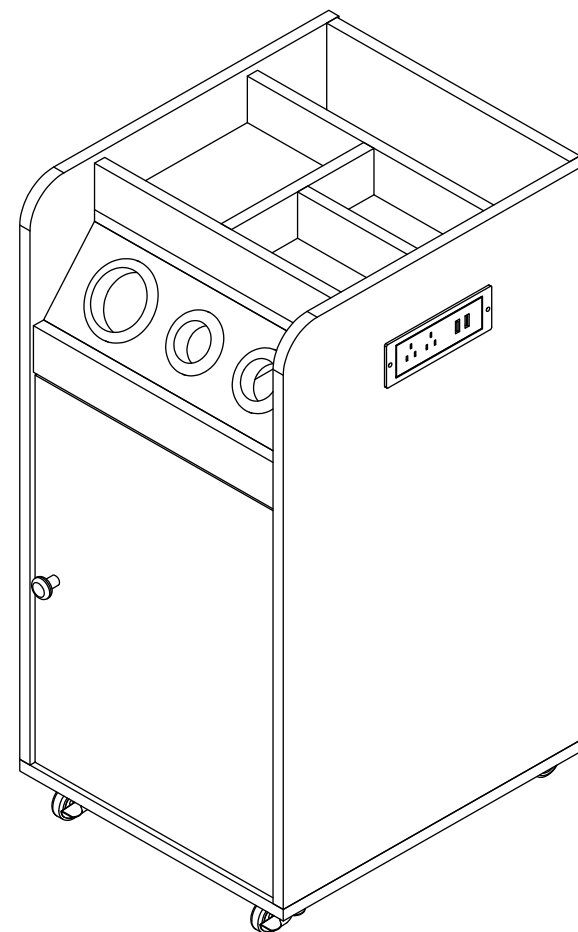

Model Number: MR11M0261



## Dear Customer,

Thank you for your purchase.

RESHABLE is created to be the perfect starting spot for any barbers. Supplying top-quality barber supplies like barber chairs, salon stations, rolling makeup cases, styling drawer cabinets, hair tool holders, and more, we help people to keep their barber store running with the best equipment at the most reliable prices.

When you receive the product, please make sure that all the parts are intact. Then please browse the entire installation manual before assembly. If problems occur unsatisfactorily as follows:

- a. The outer box is damaged.
- b. The product is damaged/bent/cracked while you open the box.
- c. The parts/accessories/assembly tools are missing.
- d. The product is hard to assemble.
- e. The instructions are not clear and can not be referred to.
- f. The product has functional problems.
- g. Other aspects that you are not satisfied with.

Please do not hesitate to contact us for help (Be sure to mark the SKU NUMBER, e.g., MR11R0246, and the TRACKING NUMBER). Our RESHABLE team with factory direct after-sales service will reply within 24 hours and do our best to resolve the problem for you. Our service is available at any time.

Sincerely,  
RESHABLE Team

**RESHABLE**  
for Profession and Creativity!

## You need

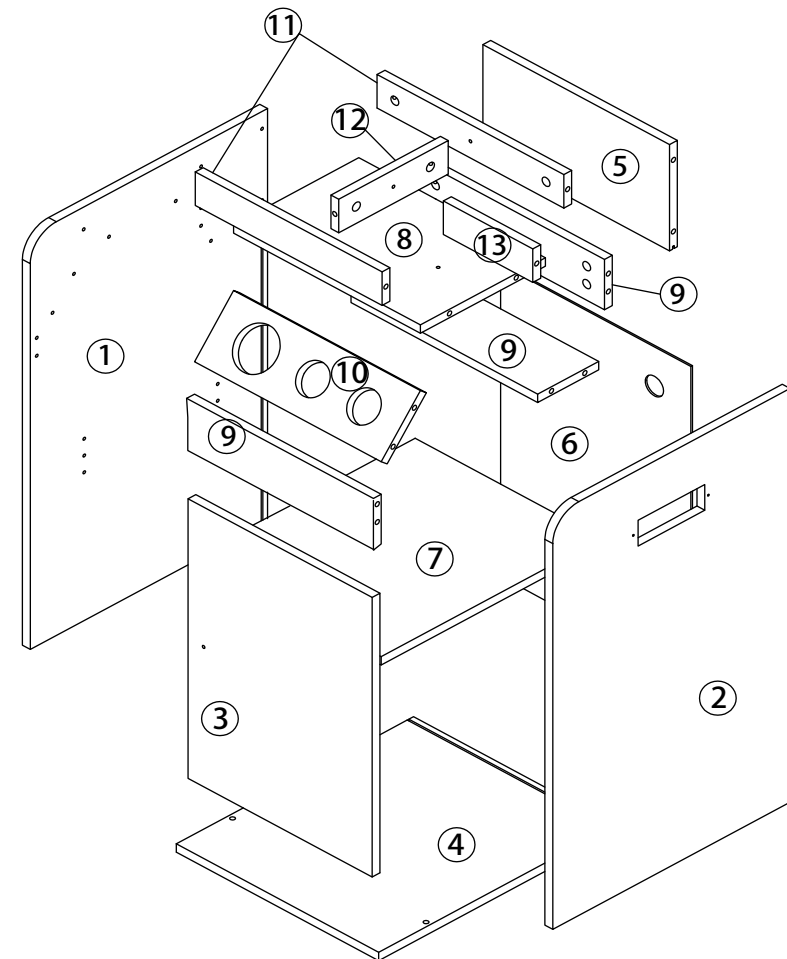
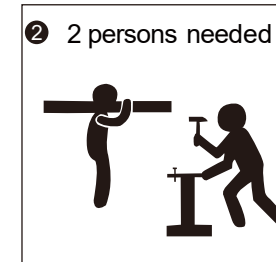
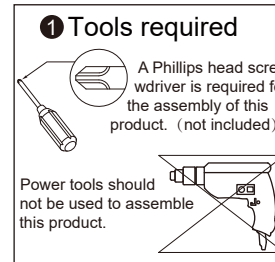

# Hardware List

① 1PC	② 1PC	③ 1PC	④ 1PC
⑤ 1PC	⑥ 1PC	⑦ 1PC	⑧ 1PC
⑨ 3PCS	⑩ 1PC	⑪ 2PCS	⑫ 1PC
⑬ 1PC	A 4PCS	B 30PCS	C 1PC
D 4PCS	E 33PCS	F 33PCS	G 1PC
H 4PCS	I 1PC	J 1SET	K 1PC
L 1PC	M 13PCS		

## PRODUCT ASSEMBLY

Check the package contents before getting started!

### STEP 1

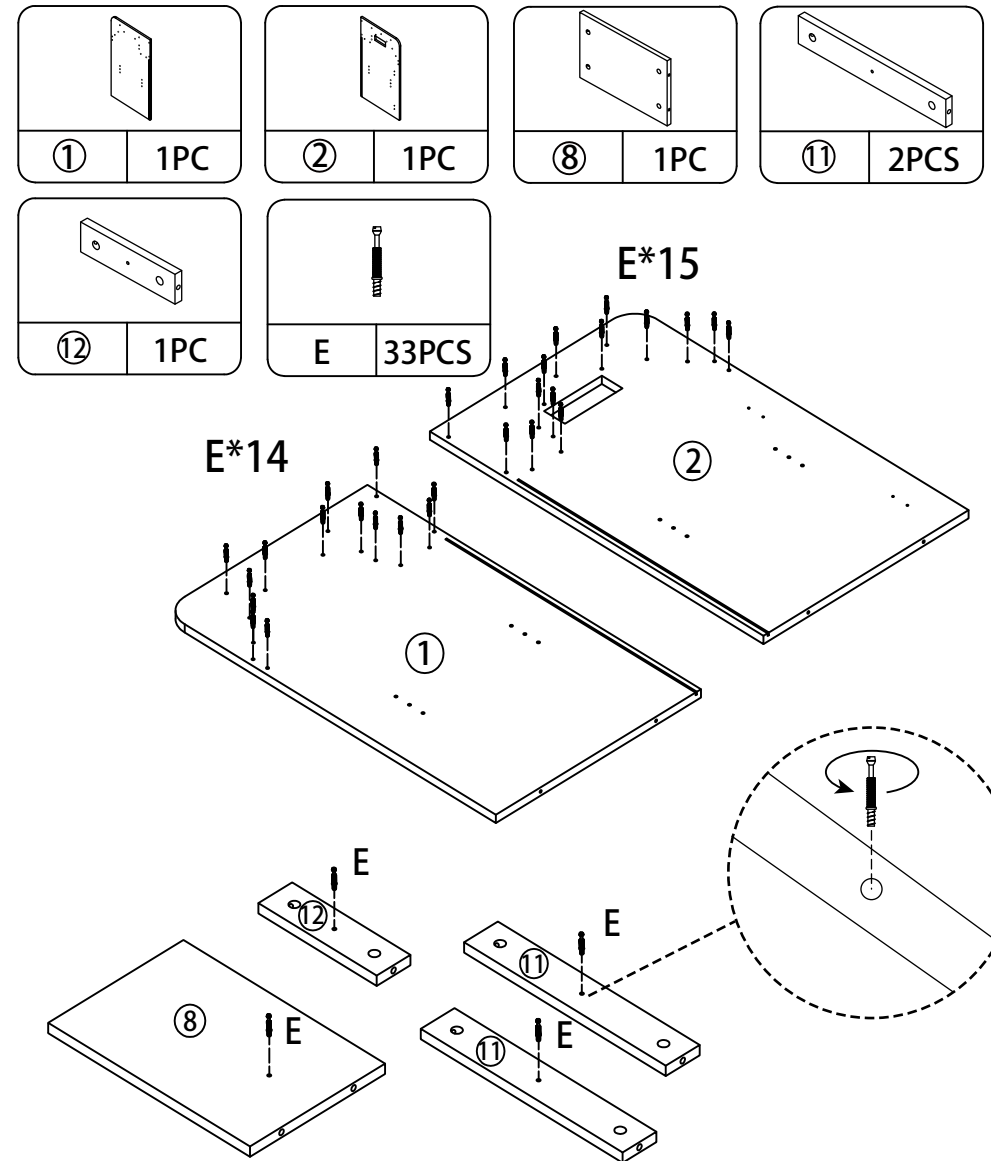

PRODUCT ASSEMBLY

STEP 2

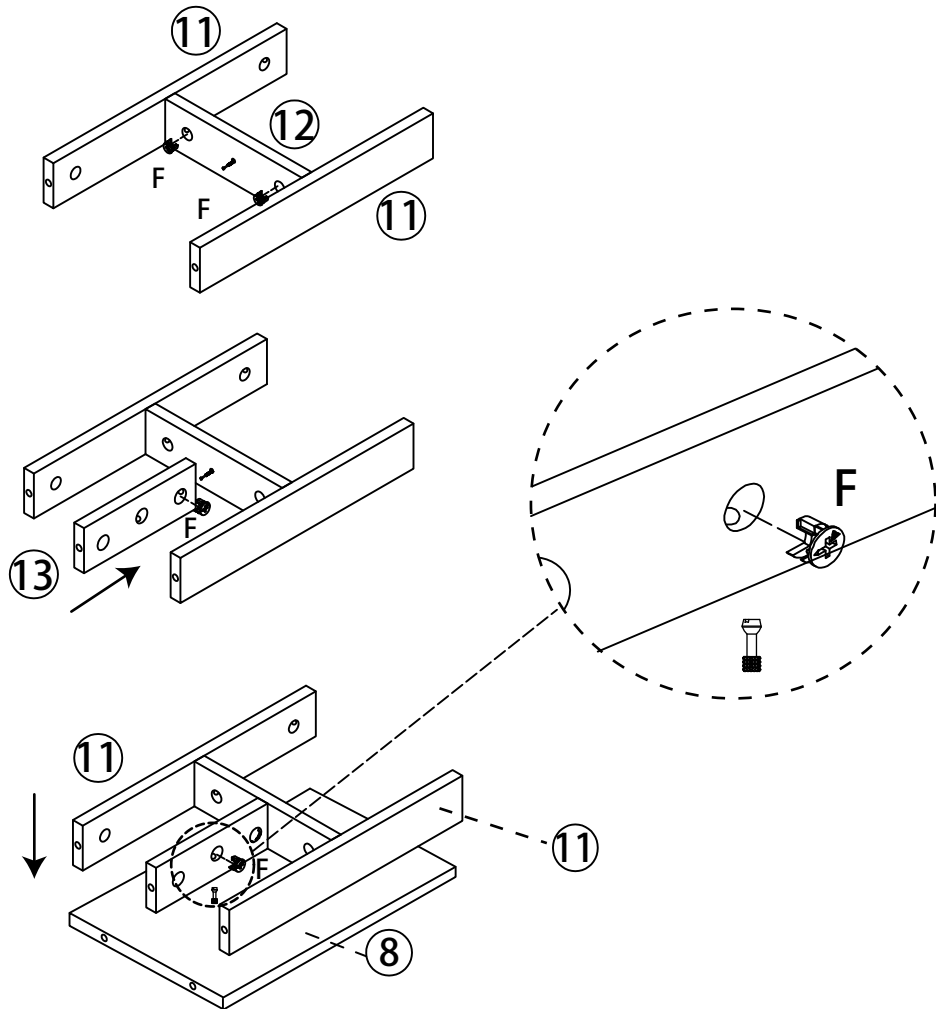
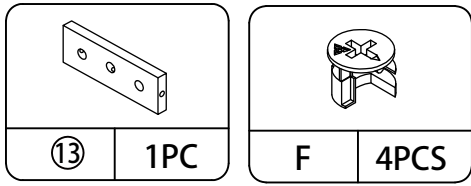

PRODUCT ASSEMBLY

STEP 3

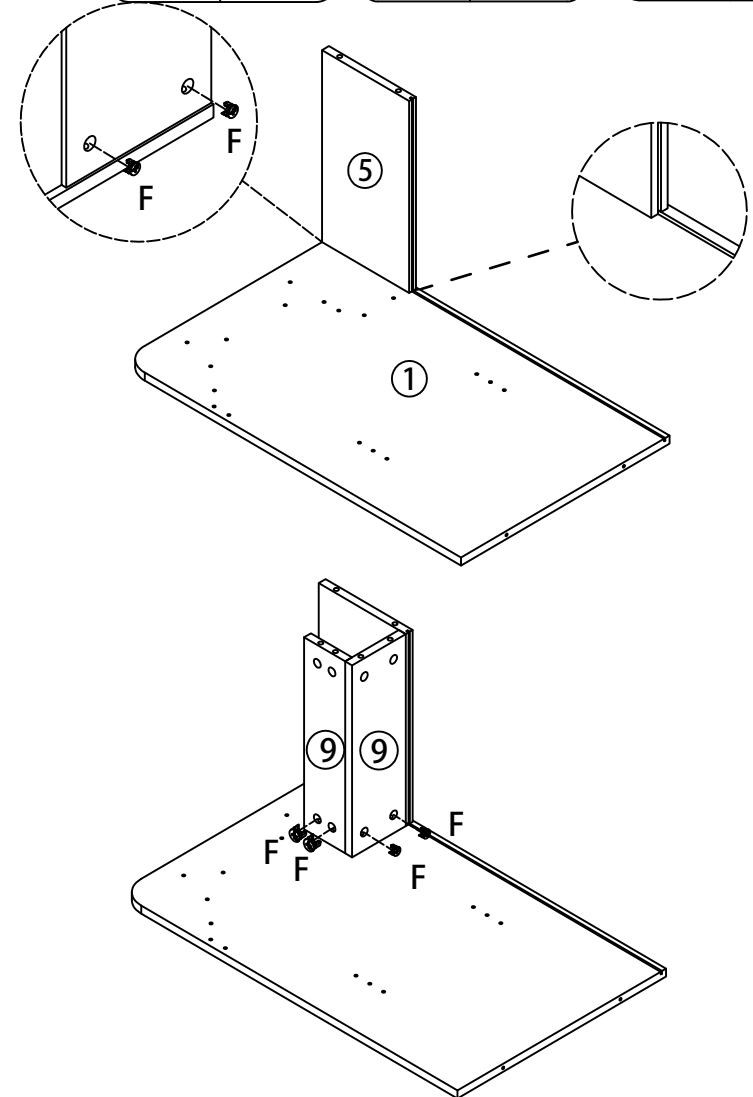
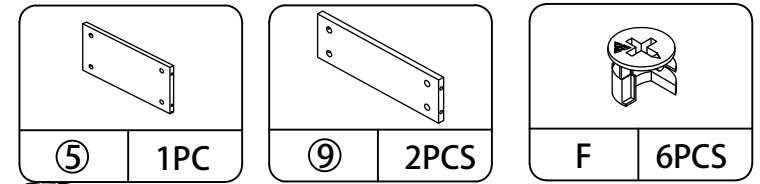

PRODUCT ASSEMBLY

PRODUCT ASSEMBLY

STEP 4

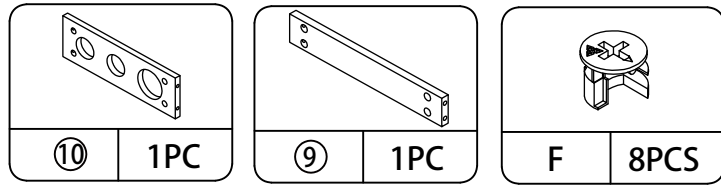

STEP 5

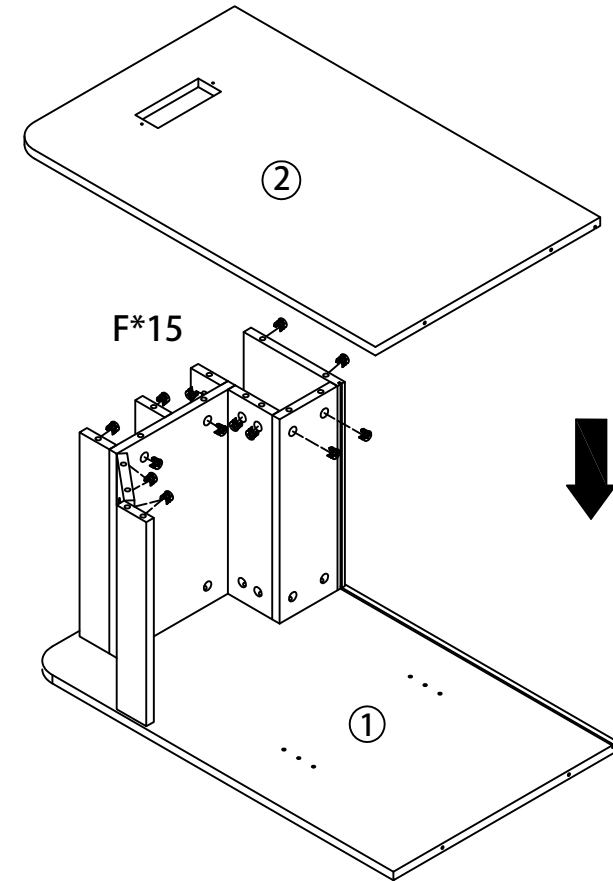
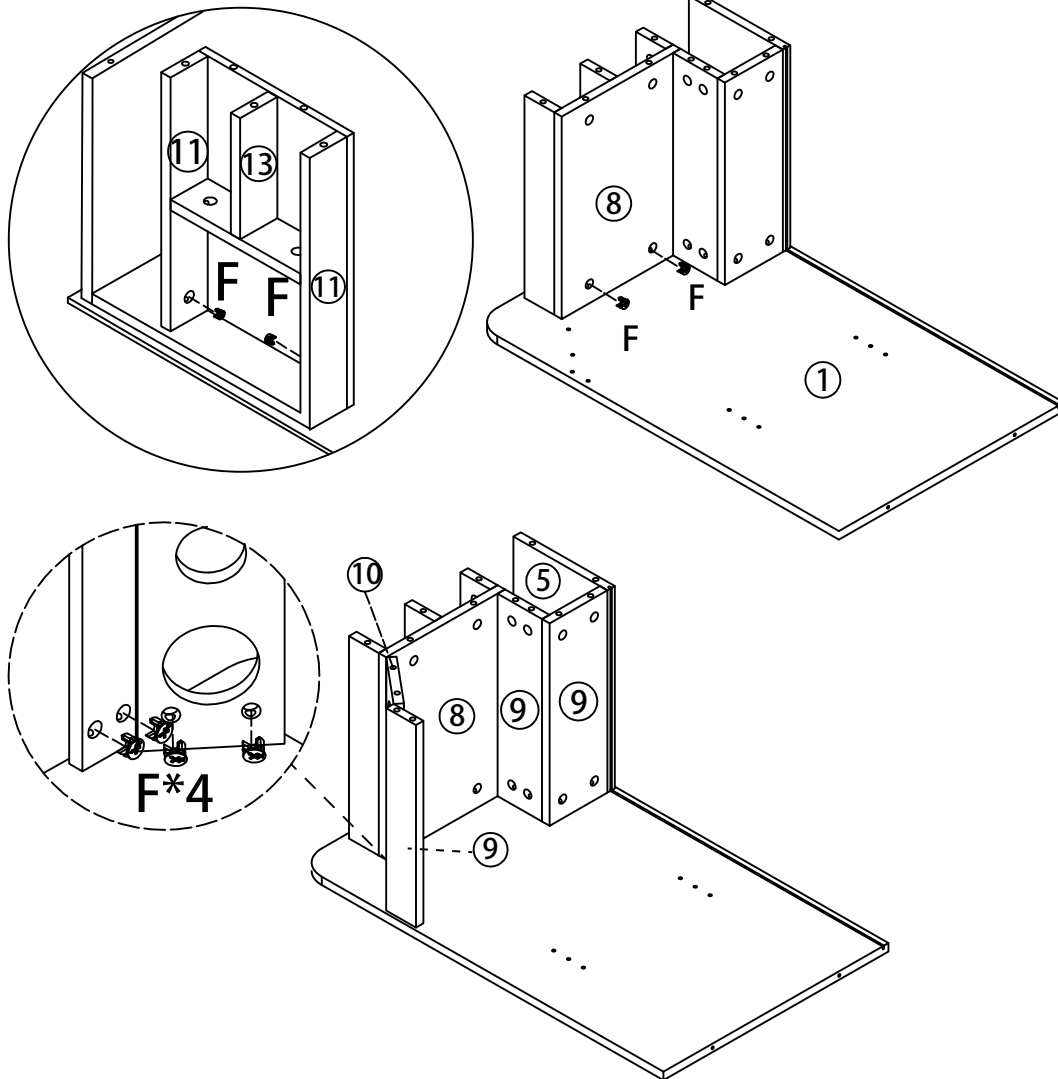
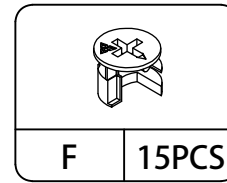

PRODUCT ASSEMBLY

STEP 6

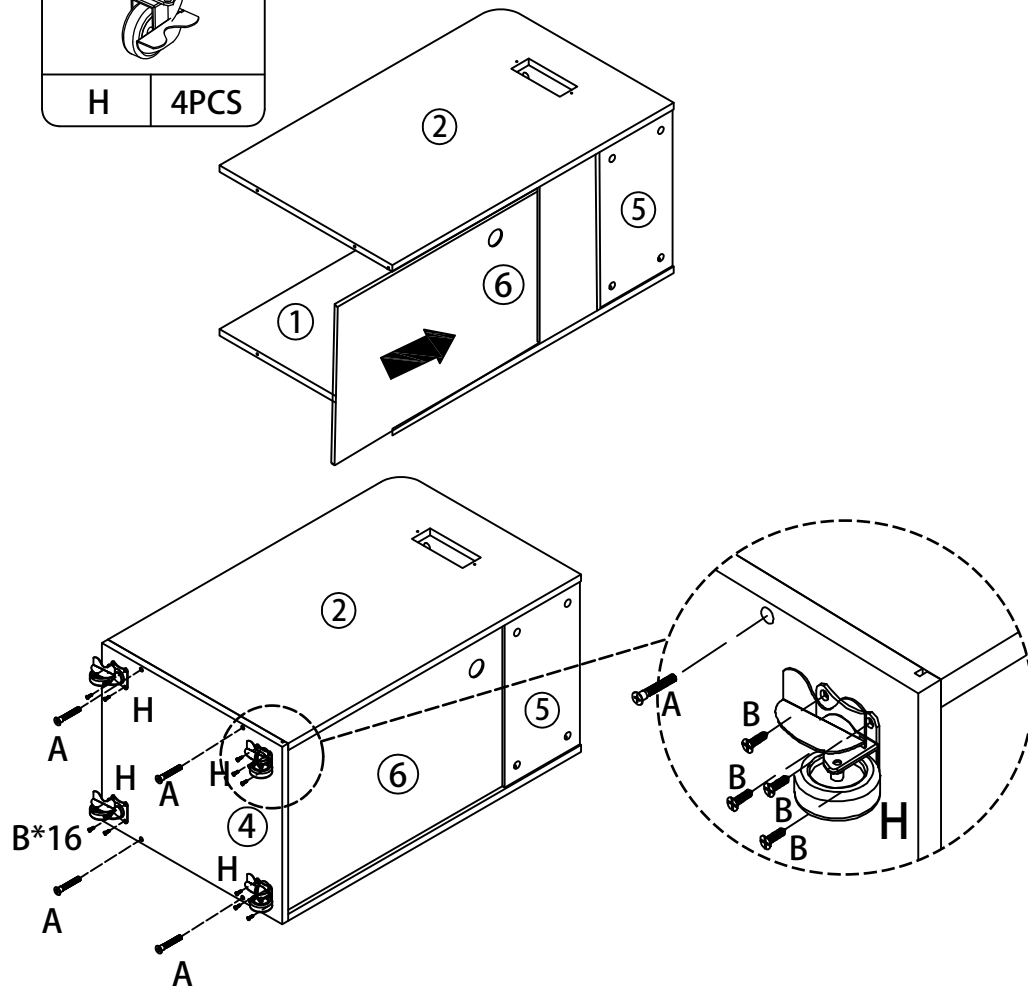
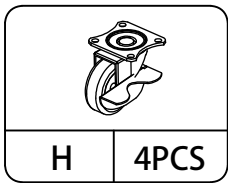
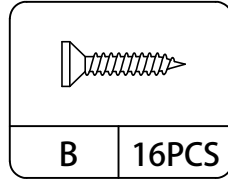
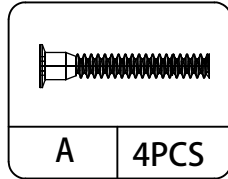
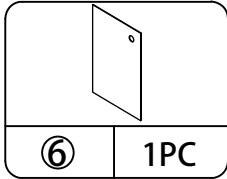
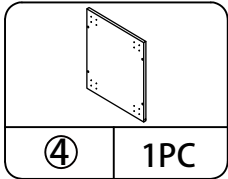

PRODUCT ASSEMBLY

STEP 7

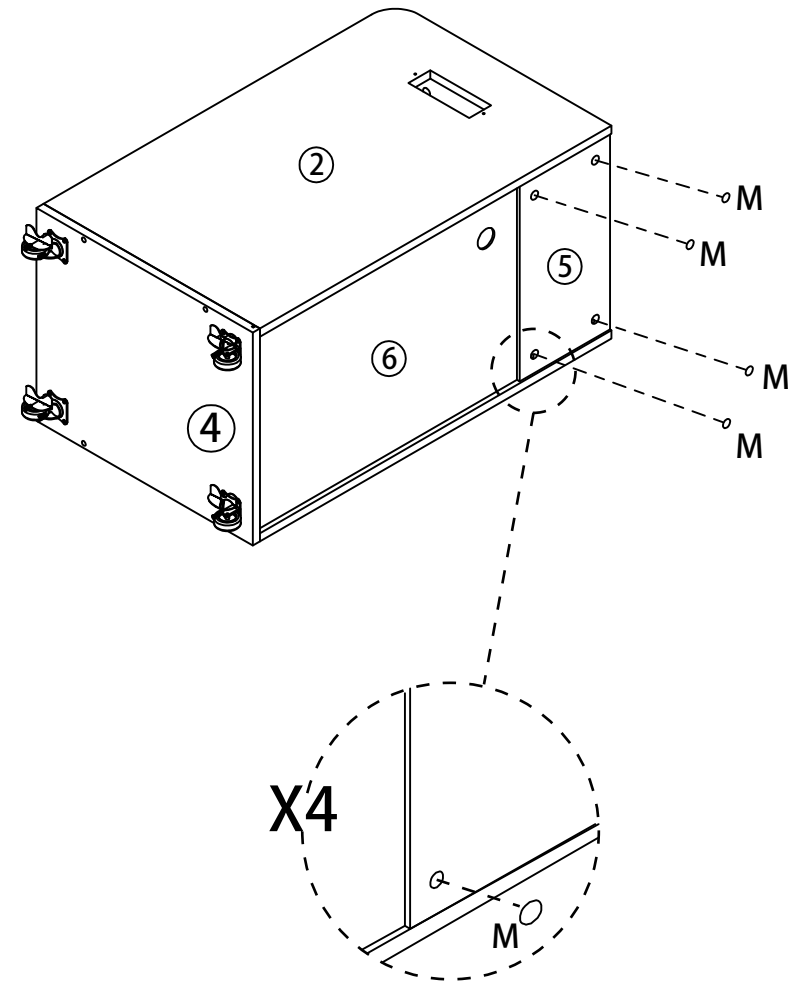
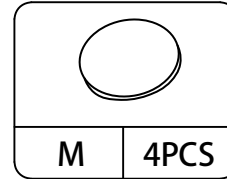

PRODUCT ASSEMBLY

STEP 8

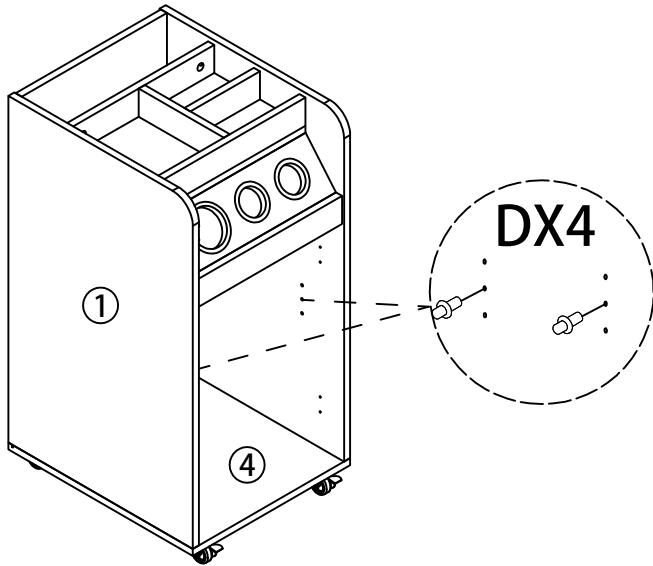
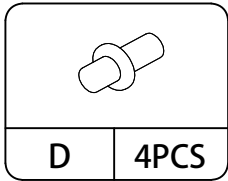

STEP 9

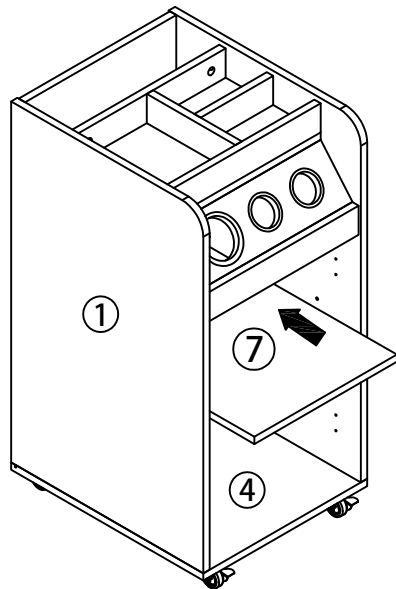
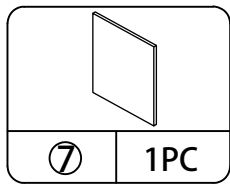

PRODUCT ASSEMBLY

STEP 10

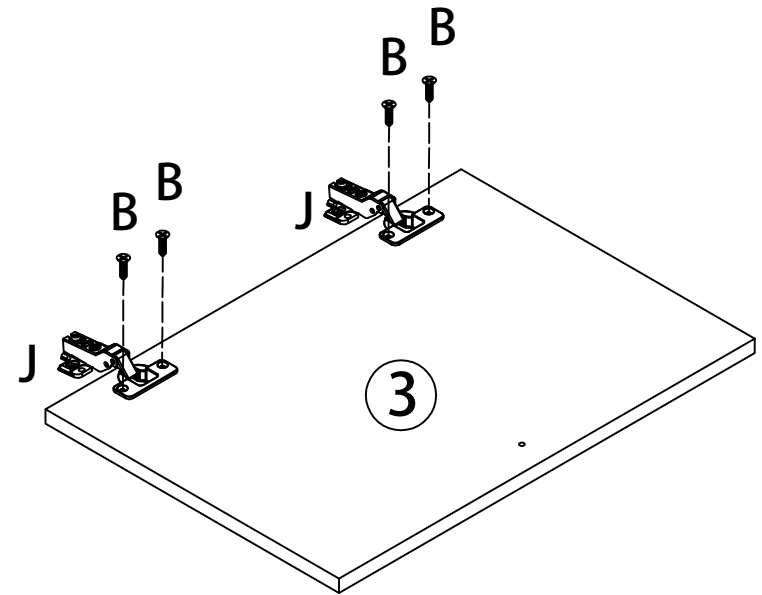
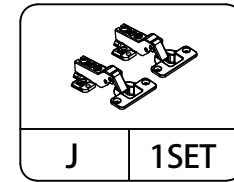
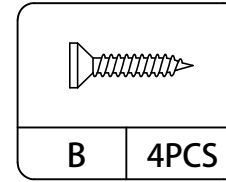
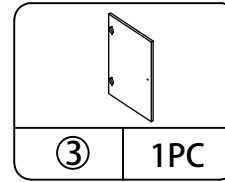

PRODUCT ASSEMBLY

STEP 11

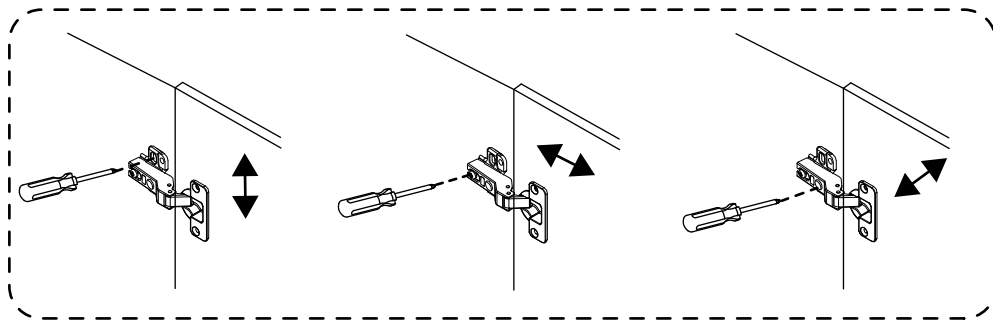
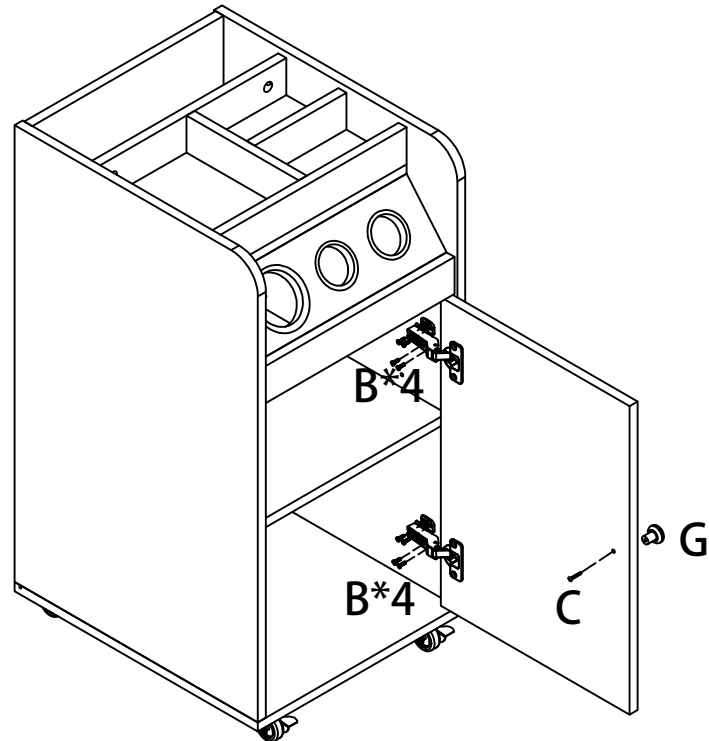
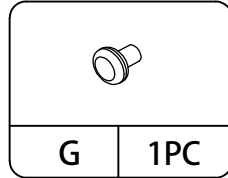
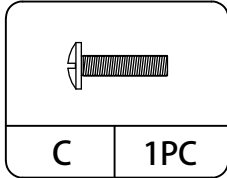
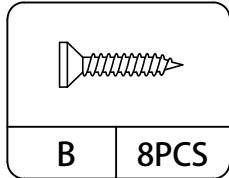

PRODUCT ASSEMBLY

STEP 12

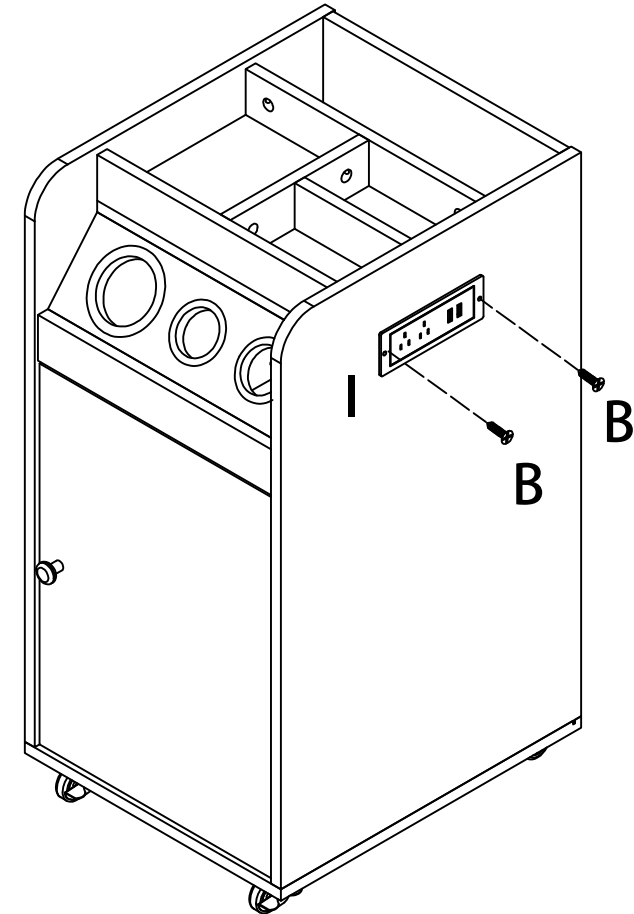
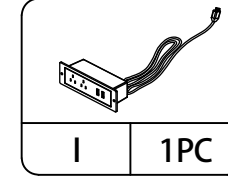
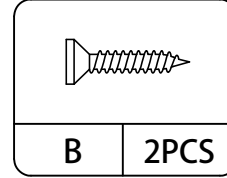



**STEP 13**

