

User Manual

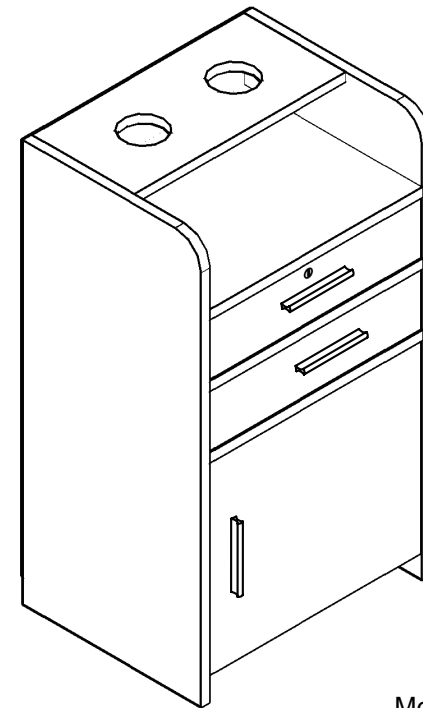

Model Number:MR11Y0180
MR11A0181
MR11B0182
MR11X0251



Dear Customer,

Thank you for your purchase.

RESHABLE is created to be the perfect starting spot for any barbers. Supplying top-quality barber supplies like barber chairs, salon stations, rolling makeup cases, styling drawer cabinets, hair tool holders, and more, we help people to keep their barber store running with the best equipment at the most reliable prices.

When you receive the product, please make sure that all the parts are intact. Then please browse the entire installation manual before assembly. If problems occur unsatisfactorily as follows:

a. The outer box is damaged.

b. The product is damaged/bent/cracked while you open the box.

c. The parts/accessories/assembly tools are missing.

d. The product is hard to assemble.

e. The instructions are not clear and can not be referred to.

f. The product has functional problems.

g. Other aspects that you are not satisfied with.

Please do not hesitate to contact us for help (Be sure to mark the SKU NUMBER, e.g., MR11R0246, and the TRACKING NUMBER). Our RESHABLE team with factory direct after-sales service will reply within 24 hours and do our best to resolve the problem for you. Our service is available at any time.

Sincerely,
RESHABLE Team

RESHABLE
for Profession and Creativity!

You need

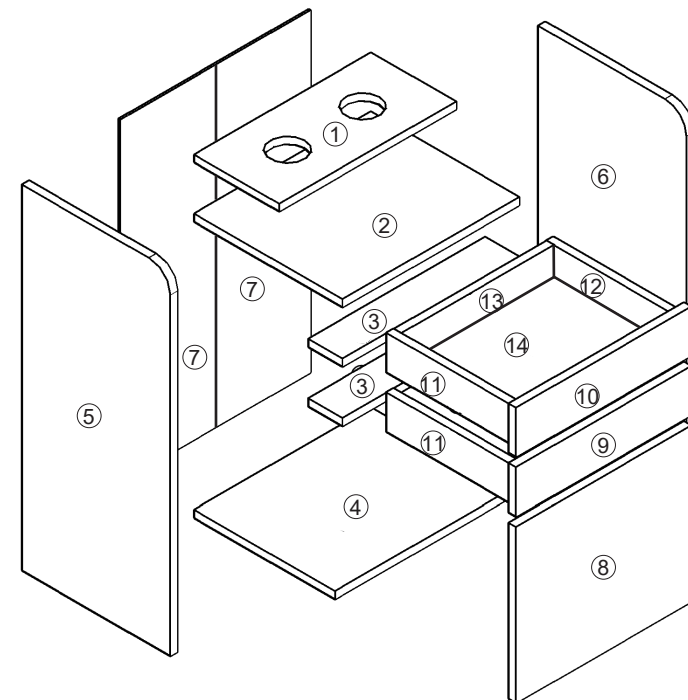
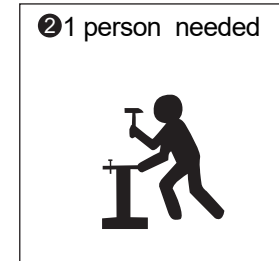
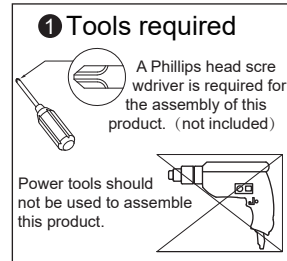

Hardware List

① 1PC	② 1PC	③ 2PCS	④ 1PC
⑤ 1PC	⑥ 1PC	⑦ 1PC	⑧ 1PC
⑨ 1PC	⑩ 1PC	⑪ 2PCS	⑫ 2PCS
⑬ 2PCS	⑭ 2PCS	M6x40mm A1 15x12mm A2 A 28SETS	8x40mm B 6PCS
C1 4SETS C2	M4x18mm 102mm D 3SETS	E 2PCS	M3.5x14mm F 44PCS
M3.5x35mm G 8PCS	H 1SET	I 2PCS	J 2PCS
17mm K 30PCS	L 2PCS		

PRODUCT ASSEMBLY

Check the package contents before getting started !

STEP 1

⑤ 1PC	⑥ 1PC	C1 4PCS	F 8PCS

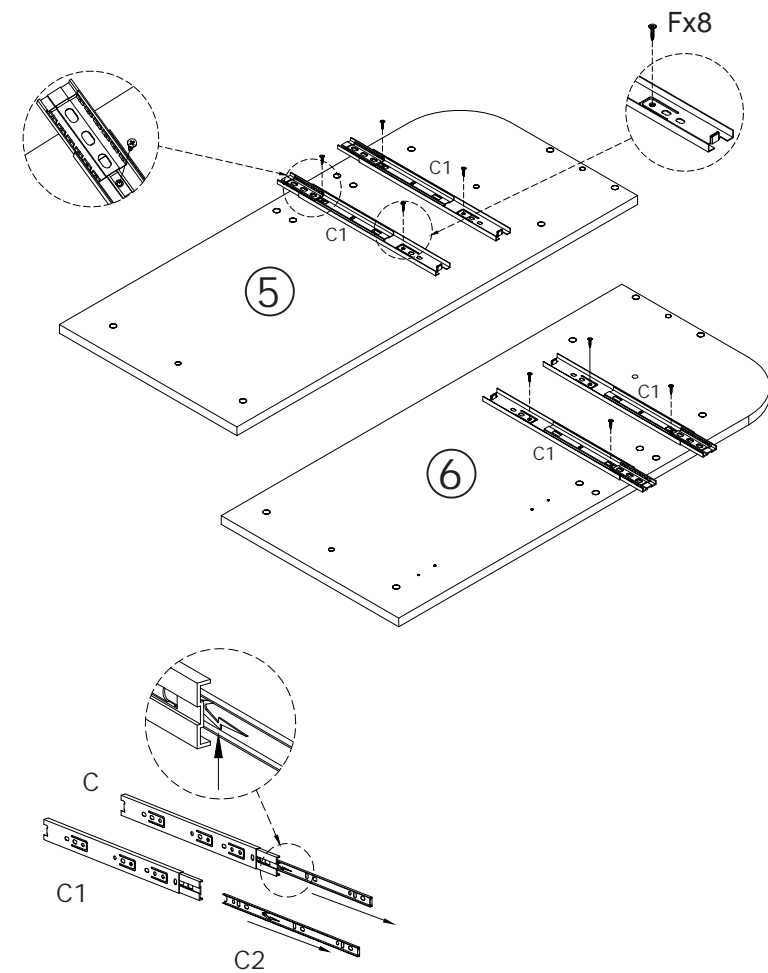

STEP 2

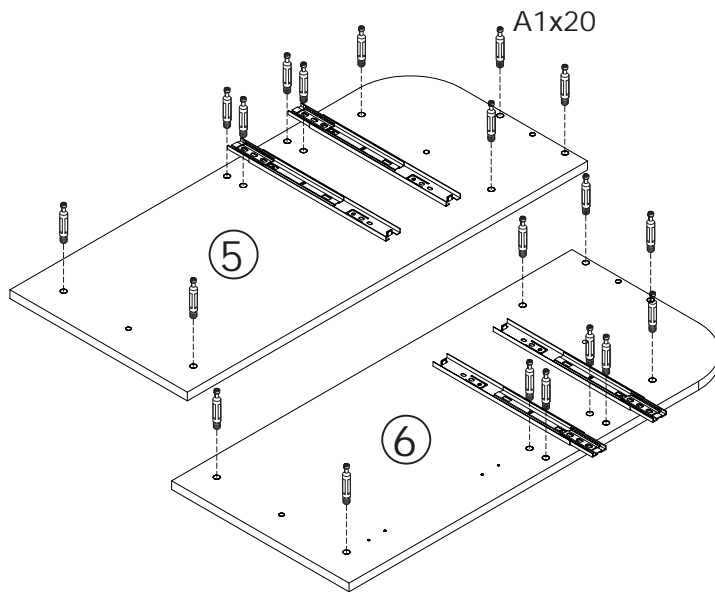
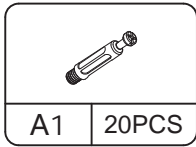

STEP 3

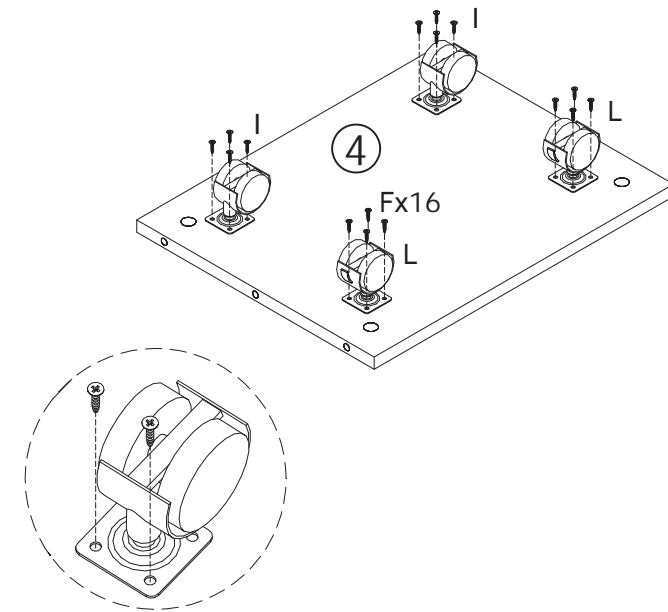

PRODUCT ASSEMBLY

STEP 4

① 1PC	② 1PC	③ 2PCS	A2 10PCS

B 3PCS

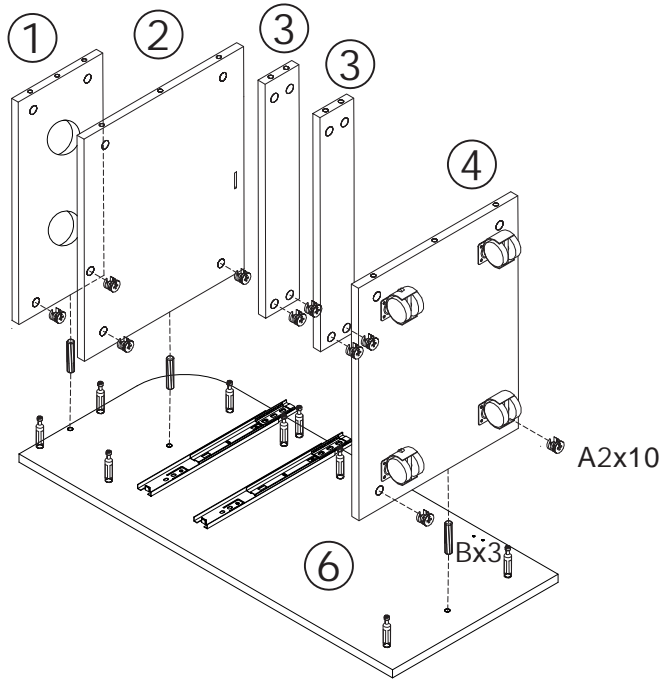

PRODUCT ASSEMBLY

STEP 5

A2 10PCS	B 3PCS

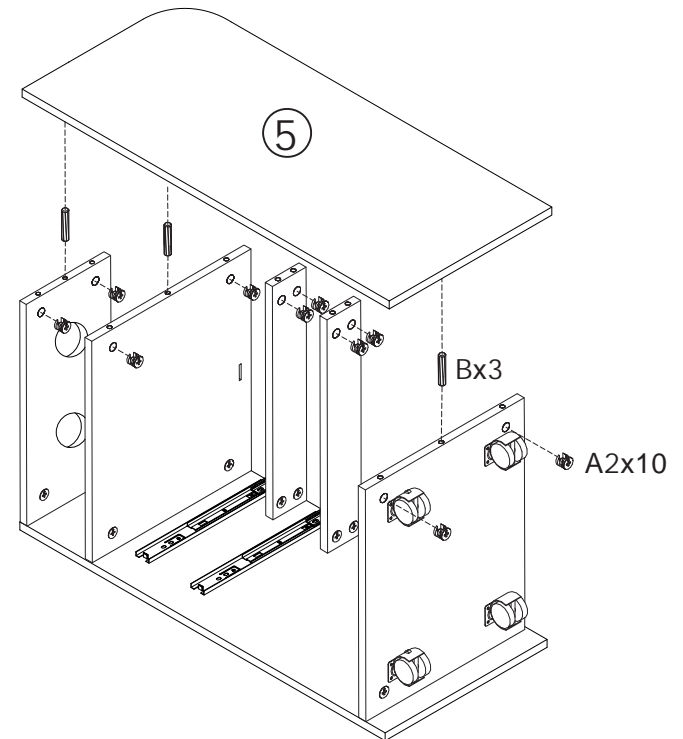

STEP 6

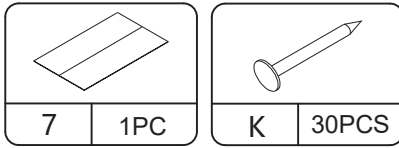

Measure the length of the two diagonal lines a and b from the back of the cabinet
And keep a and b equal in length

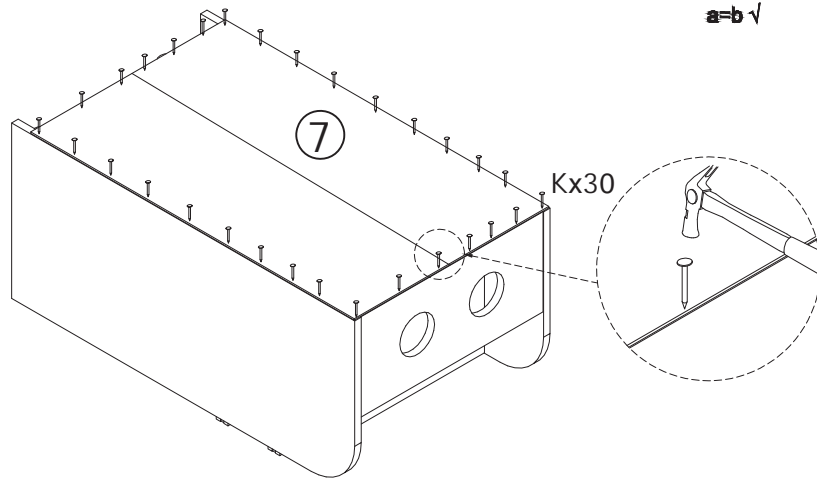
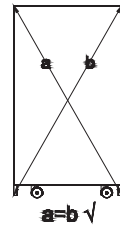

STEP 7

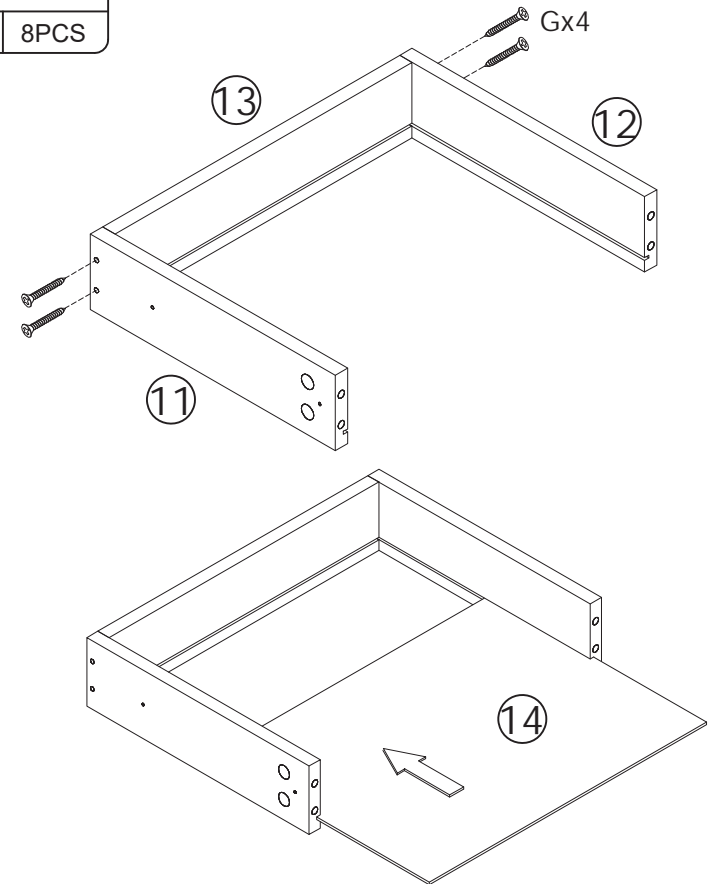
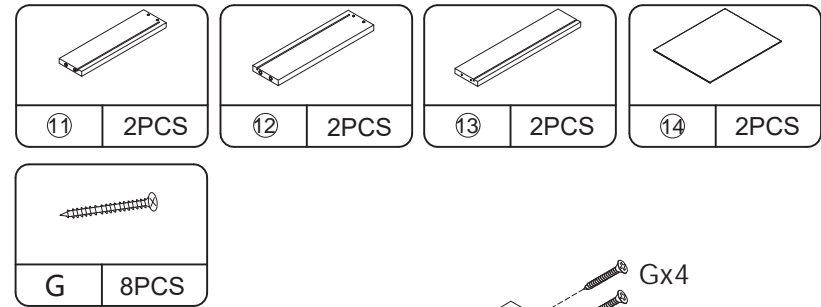

x2

PRODUCT ASSEMBLY

STEP 8

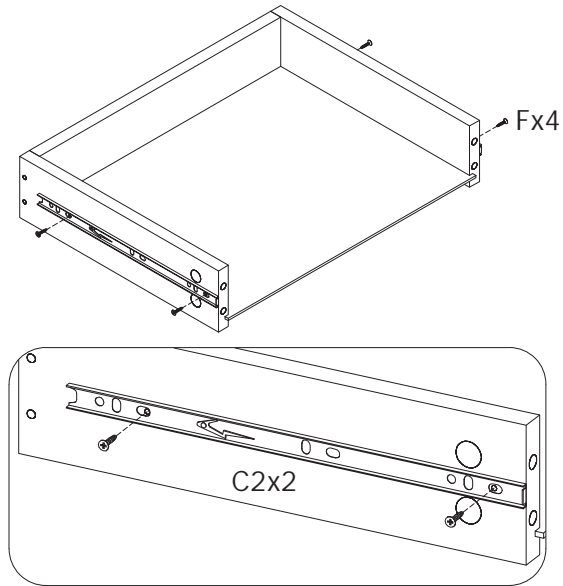
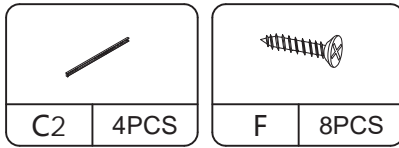

x2

PRODUCT ASSEMBLY

STEP 9

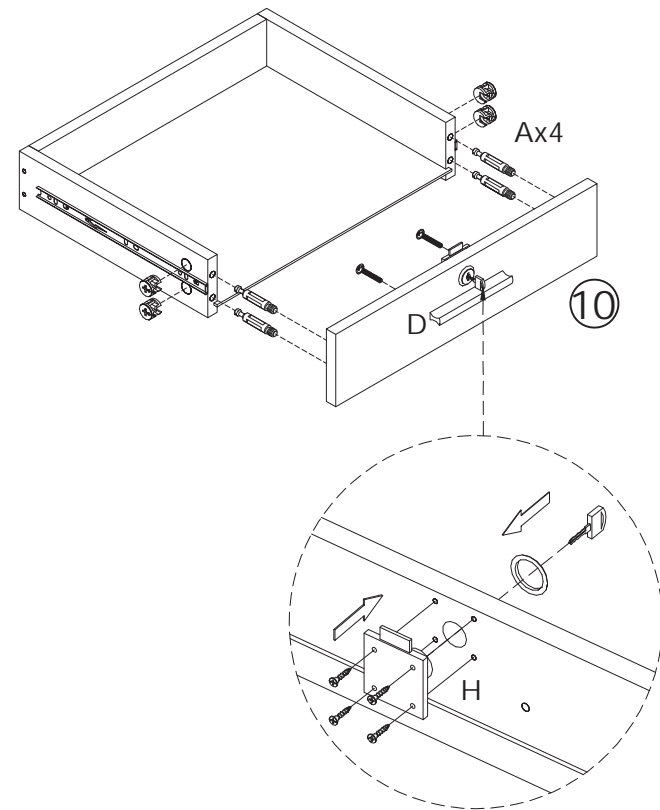
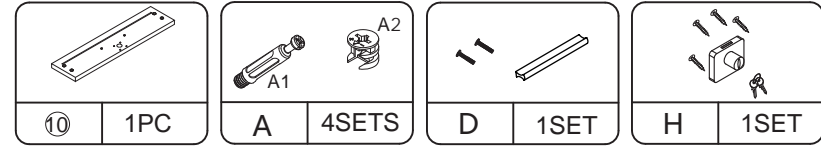

PRODUCT ASSEMBLY

STEP 10

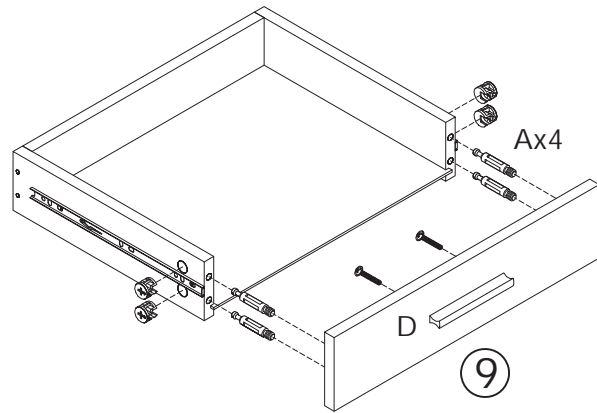
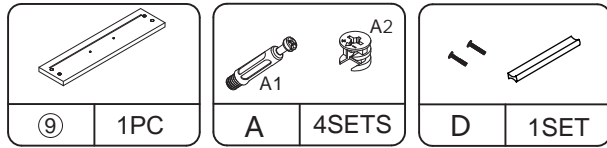

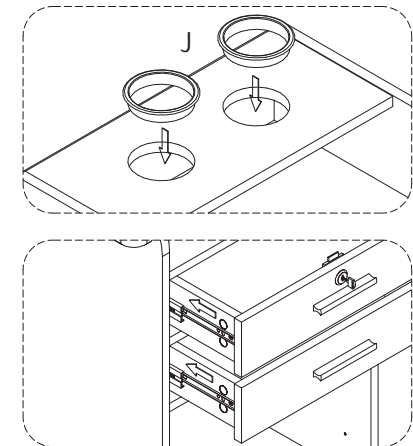
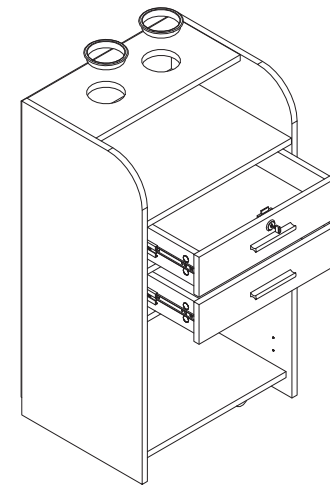
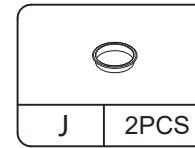

PRODUCT ASSEMBLY

STEP 11

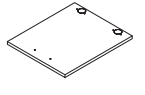
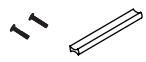

PRODUCT ASSEMBLY

STEP 12

			
⑧ 1PC	D 1SET	E 2PCS	F 4PCS

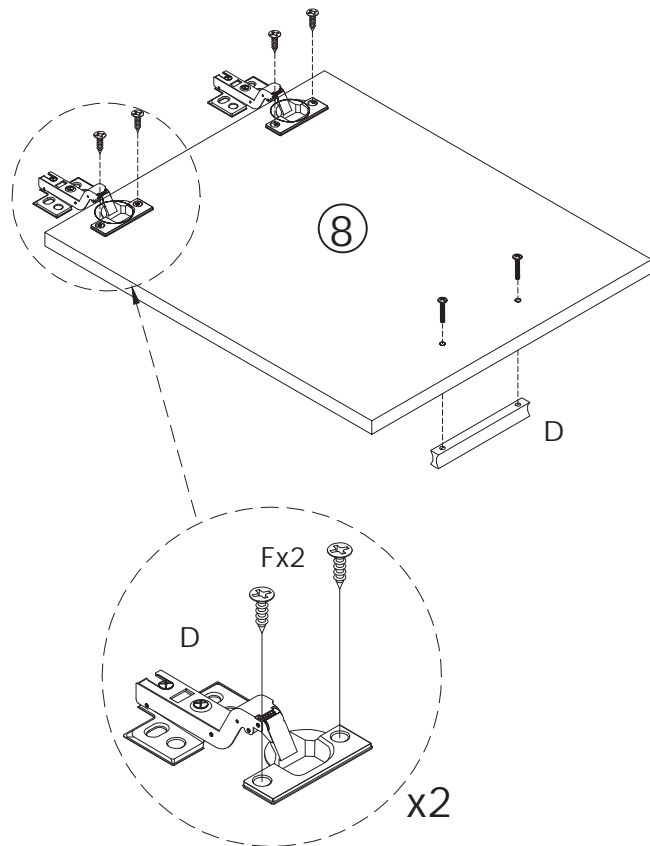

PRODUCT ASSEMBLY

STEP 13

F 8PCS

